

BrewEasy™

Assembly, Operation, & Maintenance



Congratulations on your purchase, and thank you for selecting the BrewEasy™ Adapter Lid Kit from Blichmann Engineering™. We are confident that it will provide you years of service and many gallons of outstanding beer. This manual will familiarize you with the use, assembly, and the sanitation procedures for the product.



IMPORTANT INFORMATION

PLEASE READ AND THOROUGHLY UNDERSTAND THIS MANUAL PRIOR TO USE FOR IMPORTANT SAFETY INFORMATION!

- WARNING:** Sections labeled “Warning” can lead to serious injury or death if not followed. Please thoroughly read these sections and understand them completely before use. If you do not understand them or have any questions, contact your retailer or Blichmann Engineering (www.BlichmannEngineering.com) before use.
- CAUTION:** Sections labeled “Caution” can lead to equipment damage or unsatisfactory performance of the equipment. Please read these sections thoroughly. If you have any questions, contact your retailer or Blichmann Engineering (www.BlichmannEngineering.com) before use.
- IMPORTANT:** Sections labeled “Important” should specifically be followed to ensure satisfactory results with the product.

About The BrewEasy™ :

The BrewEasy™ all grain brewing system is sold in a modular format with several optional items available to enhance and customize your system. It is also sold in several pre-bundled configurations for your ordering convenience. Therefore you may not have purchased all of the items shown below in the unpacking section. Several optional and standard items will have their own separate product manual. Please review the configuration chart in the back of this manual for required and optional items you will need for your system. Please go through this section carefully and ensure that you have all of the items that you ordered. If you are missing any parts please contact your retailer immediately.

BOILERMAKER™ BREW POTS

The BrewEasy™ requires two Blichmann Engineering BoilerMaker™ pots. The adapter lids and tubing are not designed to accommodate other manufacturer's pots. The upper pot is the mash tun and the lower pot is the boil kettle. Use the following chart to confirm that you have the correct pot sizes. Consult the BoilerMaker™ manual included with each pot for unpacking and assembly/operation instructions.

Batch Size	Mash Tun (upper pot)	Boil Kettle (lower pot)
5 gal (19 L) Batch (7.5g/10g kettles)	7.5 gal	10 gal
5 gal (19 L) Batch (10/10g kettles)	10 gal	10 gal
10 gal (38 L) Batch (15g/20g kettles)	15 gal	20 gal
10 gal (38L) Batch (20g/20g kettles)	20 gal	20 gal
20 gal (76 L) Batch (30g/30g kettles)	30 gal	30 gal

FALSE BOTTOM

In addition to the pot, you will also need to purchase a false bottom for the mash tun (upper pot). This false bottom also includes a large washer.

Note: the AutoSparge™ requires a 13/16" to 7/8" diameter hole to be drilled in the mash tun. If you purchased a bundled system, or ordered the AutoSparge™ hole punch service when you ordered your pot, it will already be drilled in the R2 position. If not, the AutoSparge™ manual provides detailed installation instructions.

What's In the Box?

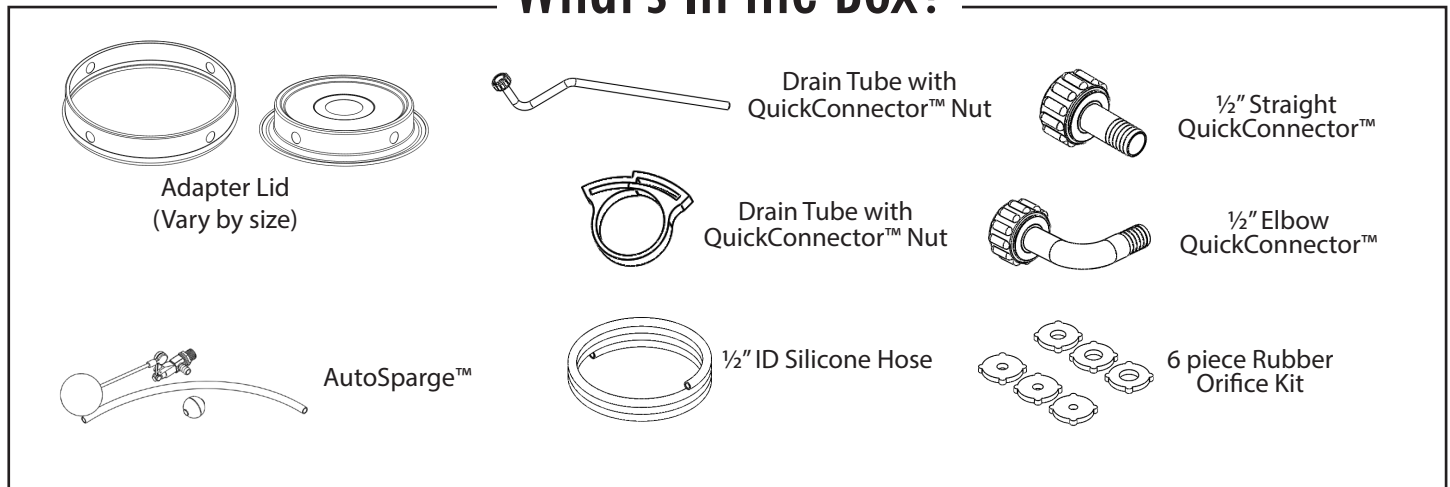

HEAT SOURCE

A single heat source for the lower pot (boil kettle) is required for operation. The upper pot (mash tun) does not need a heat source. Blichmann Engineering offers three heat source types for your BrewEasy™ all grain system. Our HellFire™ burners operate on high pressure propane, or with our optional gas orifice, will operate on natural gas. We also offer our BoilCoil™ electric immersion heaters for electric brewing systems. The BoilCoil™ electric immersion heaters may be ordered pre-installed from the factory for a nominal charge, or they may be field installed. Finally, we offer Electric Surface Heating Technology with our Surface™ concealed element electric heaters. Instructions for both propane and electric heating systems are included with the product.

Warning - Use only Blichmann Engineering HellFire™ burners, BoilCoil™ heating elements, or the BoilerMaker Surface™ with this product. Non-Blichmann Engineering approved products may cause unsatisfactory, unstable or other unsafe operating conditions, and may lead to unsatisfactory performance, serious injury or death.

PUMP

A single pump is required to operate your BrewEasy™ brewing system. The pump is used to recirculate liquid from the bottom kettle up to the top kettle during the mash. We recommend and use the RipTide™, pictured on the right.



BREWCOMMANDER™

Blichmann Engineering offers the BrewCommander™ temperature controller in both gas (propane and natural gas) and electric heater versions. It includes a full operational manual, parts list, and installation instructions.



COMMAND STAND™ AND FLOW CONTROL MANIFOLD

Blichmann Engineering offers the Command Stand™ controller stand. The tower supports your controller, pump, power, plumbing, optional chiller, and other equipment on a convenient pre-packaged stand. The Flow Control Manifold additionally offers a visual flow meter, wort sampling port, and a convenient 44" working height. While a Command Stand™ isn't required for your system, it does greatly simplify the setup and use of your BrewEasy™! Consult the Command Stand™ operational manual for a parts list and installation instructions.

COMMAND STAND™



COMMAND STAND™ ATTACHED TO BREWEASY™



ASSEMBLY

1. Assemble the accessories into both kettles following the kettle manual and respective accessory manuals

2. **Install the boil kettle** (the lower pot) if using a HellFire™ burner, adjust the retaining arms to fit the outside edge of the pot. Details are shown in the HellFire™ manual.

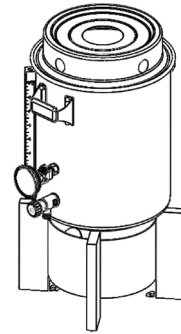

3. **Install the adapter lid** or adapter ring on the boil kettle as shown. To identify which adapter was sent with your system, refer to the “Adapter Lid Kit” section found on the previous pages of this manual.

Note: The pot lid must be removed from the lower boil kettle prior to installation of the adapter lid.

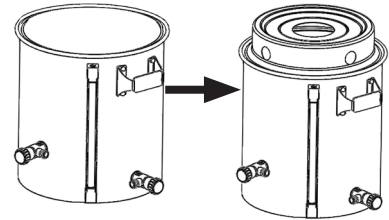

4. **Install the mash tun** (upper pot) on the top of the adapter lid as shown below. Thread the Quick Connect elbow into the mash tun drain valve.

Important: Install these fittings exactly as shown or the drain tube will not fit into the assembly!

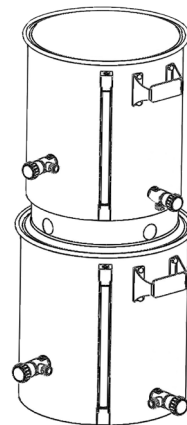

5. **Install the false bottom** into the mash tun. Refer to the BoilerMaker™ manual for installing the false bottom.

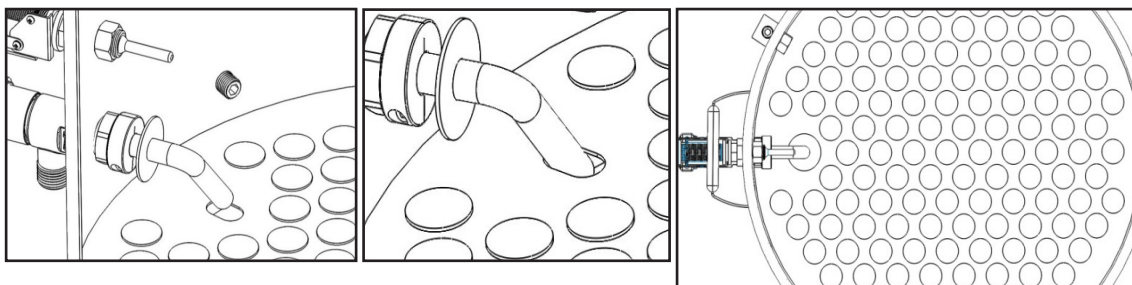

6. Install the drain tube assembly

An orifice kit is provided that will regulate the flow rate out of your mash tun to help prevent stuck mashes and to provide batch to batch consistency. Each orifice is marked with a number corresponding to the approximate flow rate in gallons per minute that will flow through the orifice as shown below. Selection of the proper orifice size will be covered in the operation portion of the manual. Slip the nut over the tube and insert the orifice into the nut as shown.

Rotate the adapter lid so that one of the side holes aligns directly under the mash tun drain valve. Insert the drain tube into the hole and thread the nut onto valve.

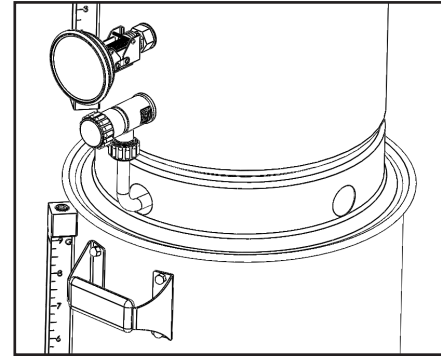
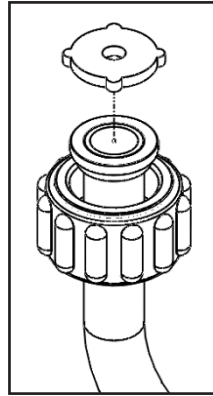
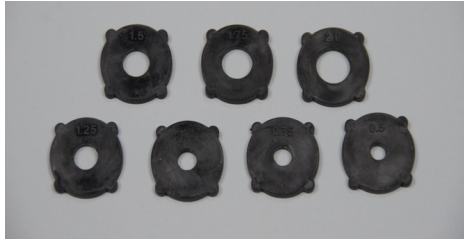

Orifice Selection: Included with your BrewEasy™ is a set of 6 flow orifices ranging from 0.5 to 2.0 gpm. This orifice will set the approximate recirculation flow rate of the system automatically and allow you to simply open and close the valves fully to direct wort flow.

Important: It is important to flow at the fastest rate that will not cause your mash to stick. Faster flow rates increase the stability of the control system and reduces the temperature gradient in the mash. It will take some experimentation to determine which orifice is best for your system. Grain crush, adjuncts, and other variables will all have some effect on how fast you can recirculate. The chart below is a good starting point.

TIP: Fortunately the BoilerMaker™ brew pot features a level gauge that can be used to warn you of impending stuck mashes. The level gauge acts as a manometer (pressure gauge) to indicate how hard you are drawing on the mash bed. If the level in the sight glass drops more than half of the starting level (with the pump off) you are drawing too fast and are risking a stuck mash. Either install a lower flow orifice or throttle the flow using the outlet valve of the mash tun. If you experience grain bed compaction troubles, it is nearly always the result of crushing your grain too finely.

Install hoses: Your BrewEasy™ system includes the necessary QuickConnector™ hose fittings and a length of high quality silicone hose. Connect another elbow QuickConnector™ fitting on the inlet to the AutoSparge™ float valve. The elbows will keep the hoses from kinking. Place a straight QuickConnector™ fitting on the inlet to the pump and the pump throttling valve.

NOTE: Teflon tape is not needed with the QuickConnector™ fittings.

Important: Place your pump in the desired location ensuring that it is at the lowest possible point in the system. A centrifugal pump will not prime and operate properly if it is installed above the liquid level in the bottom kettle. Typically the pump is positioned on the side of the product where the AutoSparge™ is installed. Ensure that the controller and pump are located far enough from the burner or pot so that the components stay cool and dry.

Install a hose between the AutoSparge™ and the pump throttling valve as shown. Cut it to the appropriate length and secure it with the provided hose clamps. Ensure that the hose does not kink and that it is routed away from heat sources that may cause it to burn. Lastly, install a hose between the brew kettle outlet valve and the pump inlet also shown. Again, ensure that the hose does not kink or come in contact with excessive heat. It is recommended to provide a little slack in the hoses to accommodate positioning the pump.

NOTE: If using the flow control manifold, the outlet of the pump will need to connect to the manifold in between the pump and the AutoSparge™.



Operation:

The BrewEasy™ is a RIMS system (Recirculation Infusion Mash System) that uses a process called Kettle RIMS. This RIMS system requires the continuous recirculation of wort through the mash tun for the following purposes:

- (1) Adding heat to the mash for step mashing
- (2) Reducing temperature gradients within the mash bed
- (3) Clarifying the wort (vorlauf)

Another key difference with this system is that you will start with ALL of your brewing liquor at the start of the brew day. This is a no sparge system! The elimination of the sparge process and separate vorlauf reduces the length of your brew day by about an hour!

System Efficiency: The BrewEasy™ system efficiency is about mid-way between a brew in a bag system and a traditional three tier fly sparging system. Most fly sparge setups achieve about 78-82% mash (conversion) efficiency on Blichmann Engineering equipment. Of course there are many variables (crush, water chemistry, adjuncts etc.) that effect the efficiency of any mashing system. The BrewEasy™ system typically achieves about 10% lower efficiency than a fly sparging system and about 10% more than a typical brew in a bag system. With the compactness, speed, ease of use and excellent repeatability, the BrewEasy™ is great system with few compromises!

Tip: As with any new system it will take a few batches to dial in your efficiency and water usage requirements. Always make careful notes, and closely follow our recommendations. If you are new to all grain brewing we suggest reading John Palmer's book "How to Brew" published by the Brewers Association, before brewing your first batch. Please note that this manual is not intended to be a complete all grain brewing text.

Water for Brewing: The full volume of water required for brewing should be treated with water salts if using distilled or de-ionized water (see Water Chemistry for more information). Otherwise, carbon-filtered city water (carbon filtering removes chlorine), well water, or un-chlorinated spring water would be acceptable. If your water source is known to have very hard water, you are not able to use a carbon filter, or your water is treated with a water softener, it is advisable to follow the water chemistry techniques outlined in the Water Chemistry section below.

Water Chemistry: Water chemistry varies depending on the location of the source and what was done to treat the water. The most predictable way to control the quality of the water, particularly if you are unsure of your local water chemistry, is to start with pure water (distilled, deionized, or reverse osmosis) and add your own minerals to the water. This ensures that the mash is at the correct pH so that the grains are more efficiently converted to sugars, and the proper pH avoids extracting astringent flavors from the husks. To get started, you will need some raw ingredients, easily found at your local homebrew supply store: Gypsum (Calcium Sulfate, CaSO_4), Calcium Chloride (CaCl_2), and Baking Soda (also found in your local grocery store). Next, use the chart on the following page to select the proper water treatment.



Important: Multiply the unit of measure by how many gallons you will be mixing at a time. Stir well to ensure the ingredients completely dissolve. There may be some cloudiness initially; this is acceptable.

Tip: John Palmer & Cameron Kaminski's book "Water" published by the Brewers Association, covers this topic in great detail, and is a recommended resource for all grain brewers.

	Gypsum (CaSO_4)		Calcium Chloride (CaCl_2)		Baking Soda (NaHCO_3)	
	tsp/gal	g/gal	tsp/gal	g/gal	tsp/gal	g/gal
Pale Hoppy	1/4	1	1/8	0.5	0	0
Pale Malty	1/8	0.5	1/4	1	0	0
Amber Hoppy	1/4	1	1/8	0.5	1/16	0.5
Amber Malty	1/8	0.5	1/4	1	1/16	0.5
Dark Hoppy	1/4	1	1/8	0.5	3/16	1
Dark Malty	1/8	0.5	1/4	1	3/16	1

System Overview: The figure to the right is a schematic of the overall BrewEasy™ KettleRIMS process. Note that the system is a continuous recirculation RIMS process. The arrows indicate the direction and path of the continuous flow. The mash tun is positioned above the boil kettle so that it will drain by gravity, and flow from the mash tun into the boil kettle. A pump is used to move the wort from the boil kettle back into the mash tun. An AutoSparge™ level control is utilized to gently return the wort to the top of the mash bed to prevent channeling. In addition, it prevents an accidental overflow of the system should the mash stick or the drain tube or valve plug for any reason. The orifice installed in the drain tube sets the flow rate for the system automatically. Heat is added only to the boil kettle. The temperature of the wort is sensed in the lower kettle and heat is added automatically as needed.

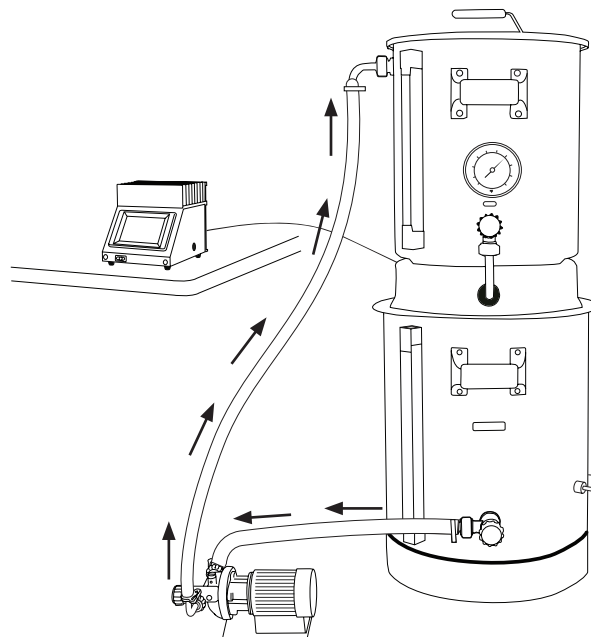

Filling Your System: Calculate the total water needed for your brew day. This should include grain absorption, boil off, and wort lost in your mash tun dead space, brew kettle dead space, and other downstream losses including shrinkage from cooling. Most brewing software such as BeerSmith and ProMash help you calculate these parameters. With a little experimentation you will be able to easily predict the water usage. Top up water can always be added to the boil kettle. If the target starting volume is exceeded you will either need to boil longer, or add extract to compensate.

Close all valves and place about half of the brewing liquor in the mash tun and the remainder in the boil kettle. Adjust the position of the AutoSparge™ arm by loosening the wing nut and moving the arm so that the sliding piston is in the open position as shown in the figure below. This ensures that the valve is in the open position and the water can flow freely as you turn on your pump and begin heating the liquor to strike temperature. The levels in both pots will automatically adjust as you begin flowing. Consult your AutoSparge™ manual for detailed information

Important: it is imperative that the AutoSparge™ level control valve is open or your pump will be air locked and will not flow!

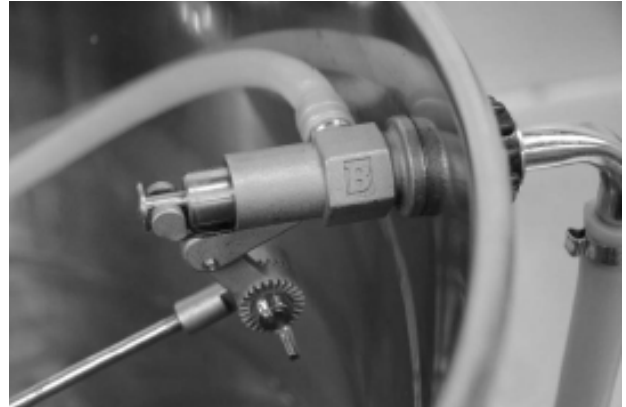

Heat to Strike Temperature: Open all valves fully and then turn on your pump. Add any water salts and acids at this time. Turn on your heat source until you reach your desired strike temperature. At this time close all valves and turn off the pump.

Tip: If excessive water is spraying out the end of the AutoSparge™ level control valve, this can be quickly corrected by partially closing (throttling) the pump flow valve until the bypass flow is reduced. Some bypass is normal and is not detrimental to the wort.

Caution: Adding grains while the pump is on will likely cause the pump to airlock and the mash to stick! Always turn off the heat source, turn off the pump, and close all valves prior to adding the grains.

Add Grains: Gently add the grist to the mash tun stirring as you add the grains. After all grains have been added, readjust the AutoSparge™ float arm as shown in the figure to the right. The middle of the float ball is about 1-2" (25-50mm) above the grain when lifted up fully into the "off" position. The idea is to have about 1-2" of liquor above the grain bed at all times while recirculating. This reduces the chance for channeling in the grain and evenly distributes the recirculated wort over the top of the mash bed.

Let the grain sit (dough-in) for about 10 min to absorb the liquor and for the air to purge out of the grain. An occasional gentle stirring will break up any clumps and release air pockets. The doughing-in process is vital for problem free recirculation. Turning on the pump before this dough-in process is complete will likely cause an airlock in the pump and a stuck mash!



Begin Recirculation: At this time, open all valves and turn on the pump. In a minute or so the AutoSparge™ level control valve will automatically trim the flow to match the flow through the orifice. Readjust the position of the float ball if needed to achieve 1-2" of wort above the grain bed. Recirculating during the mash will clarify the wort and eliminate the vorlauf process (wort clarification) and save time. It will also reduce temperature gradients in the mash bed (stratification). In addition, you can easily add heat to make up any temperature losses in the system to maintain the desired mash temperature and ramp to other rest temperatures. Blichmann Engineering offers the BrewCommander™ control system to automate this process, providing ultimate accuracy and repetition!

During the Mash: After about 10-15 min all the liquor has been recirculated approximately one to two times and the wort is an even consistent temperature. At this time take a pH reading using a quality digital pH meter. Your pH should be between 5.1 and 5.4 pH when measured at mash temperatures (145-160F, 63-71C). If the sample has cooled to room temperature your reading should be in the 5.2-5.6 pH range. If your mash is not in the desired range you will need to add more calcium into your mash or add an acid (we recommend phosphoric) to acidulate the mash.

Tip: Make sure that the thermometer in the boil kettle is actually in the wort or it will not read accurately. If it is not submerged, simply lower the float ball in the mash tun and that wort will be drained into the boil kettle.

Important: Do not skip the pH measurements! If your mash is much above the recommended pH you risk astringency in your beer among other detrimental changes. Adding water salts and acid may be necessary to achieve proper pH in any all grain brewing system.

Important: Stir (rake) the top 1/3 of the mash bed about every 15 minutes to break up any channels in the mash bed that may have formed. Do NOT disturb the bottom 2/3's of the bed as this is acting as the filter in the system. Periodically raking the mash will increase your efficiency and ensure an even temperature throughout the mash bed for more repeatable results.

Tip: Periodically measure the specific gravity. Since you have added all of the brewing liquor into your mash, SG is the same as your pre-boil wort SG! This is a great feature of the BrewEasy™ process and allows you to quickly make adjustments to your wort such as adding extract, water, or mashing a bit longer.

Completion of Starch Conversion: At the completion of your mash your wort will be quite clear. Turn off the pump and close the valve on your lower boil kettle. Leave the valve on the mash tun fully open. Turn on your heat source to begin bringing the wort to a boil. The wort in the mash tun will drain into your brew kettle automatically. It is not necessary to slow the flow down in the mash tun.

Tip: A slight increase in efficiency can be gained by reducing the flow out of the mash tun when the liquid in the level gauge reaches the height of the valve. This allows more time for the wort to permeate through the spent grains and reach the drain dip tube before it loses its siphon. Slowly move the valve handle toward the closed position until the rate of draining (as viewed in the level gauge) is about half of the full flow position. This is a completely optional step. In about 20 minutes your wort will have completely drained from the mash tun. Simply scoop out the spent grains and then remove the drain tube and the hose connected to the AutoSparge™ flow valve. Then remove the mash tun and adapter lid from the boil kettle. Your wort should now be getting close to the boiling point.

Warning: Keep a close eye on the boil kettle temperature! DO NOT bring the wort to a boil with the mash tun on top of the boil kettle. Turn the heat down or off if the temperature is above 200F (93 degrees C) when you are still draining from the mash tun. A boil-over will cause hot wort to flow out of the large vent holes in the adapter lid and may cause severe burns!

Take a final volume and specific gravity reading of your wort and record. If you are not at the desired specific gravity you can add extract or water to compensate. At this point, boil and add hops as you would any batch.

After Use Cleaning, Storage, and Maintenance:

Cleaning the BrewEasy™ is very straight-forward. Start by cleaning the adapter lid with a mild detergent (non-chlorine) or Powdered Brewery Wash (PBW) after use. Rinse the drain tube with hot water or soak in a pail of PBW to remove any soils inside the tube. Soak the hoses in a PBW solution, rinse with hot tap water and soak in a non-chlorine sanitizer. Hang to dry. Note: Iodophor will leave a harmless brown stain on the hoses. StarSan, our recommended sanitizer, will not cause any staining. Please consult the individual product manuals for the proper cleaning methods for the BoilerMaker™ pots, Riptide™ Brewing Pump, and any other brewery equipment accessories.

Blichmann Engineering™ Product Warranty

A. Lifetime Warranty

1. Blichmann Engineering provides a lifetime warranty to the original purchaser that this product will be free from manufacturing defects in material and workmanship. This is limited to the kettle construction and any welded fittings on the kettle. It also includes the element, bonding of the element to the kettle, thermal breaker, and electrical wiring components that they will be free from manufacturing defects in material and workmanship.
2. This product is for home use only. The limited warranty covers only those defects that arise as a result of normal use of the product and does not cover any other problems, including, but not limited to, those that arise as a result of:
 - a. Improper maintenance or modification;
 - b. Damage due to incorrect voltage or improper wiring by customer;
 - c. Operation outside of the product's specifications;
 - d. Carelessness or neglect to operate the product in accordance with instructions provided with the product;
 - e. Damaging the tamper label on the product;
 - f. Damage by over-tightening the fasteners;
 - g. Failure to follow cleaning and / or maintenance procedures; or
 - h. Exceeding published operational temperatures.
3. Blichmann Engineering reserves the right to request delivery of the defective component for inspection before processing the warranty claim. If Blichmann Engineering receives, during the applicable warranty period, notice of a defect in any component that is covered by the warranty, Blichmann Engineering shall either repair or replace the defective component with a new or rebuilt component at Blichmann Engineering's option.
4. Blichmann Engineering must be notified within seven (7) days of the delivery date of any shipping damage. Customer is responsible for shipping damage outside of this time period. Approval for return must be provided by Blichmann Engineering prior to any return. Customer is responsible for keeping all original packaging material for warranty returns. Blichmann Engineering is not responsible for damage from improperly packaged warranty returns, and these repair costs will be the sole responsibility of the customer. Shipping costs for warranty returns are covered only for the contiguous United States.
5. Blichmann Engineering's limited warranty is valid in any country where the product is distributed.

B. Limitations of Warranty

1. Any implied warranty that is found to arise by way of state or federal law, including any implied warranty of merchantability or any implied warranty of fitness, is limited in duration to the terms of this limited warranty and is limited in 1 scope of coverage to this warranty. Blichmann Engineering disclaims any express or implied warranty, including any implied warranty of fitness for a particular purpose or merchantability, on items excluded from coverage as set forth in this limited warranty.
2. Blichmann Engineering makes no warranty of any nature beyond that contained in this limited warranty. No one has authority to enlarge, amend, or modify this limited warranty, and Blichmann Engineering does not authorize anyone to create any other obligation for it regarding this product.
3. Blichmann Engineering is not responsible for any representation, promise, or warranty made by any independent dealer or other person beyond what is expressly stated in this limited warranty. Any selling or servicing dealer is not Blichmann Engineering's agent, but an independent entity.

C. Limitations of Liability

1. The remedies provided in this warranty are the customer's sole and exclusive remedies.
2. Except for the obligations specifically set forth in this warranty, in no event shall Blichmann Engineering be liable for direct, indirect, special, incidental, or consequential damages, whether based on contract, tort, or any other legal theory and whether or not advised of the possibility of such damages.
3. This warranty does not cover, and in no event shall Blichmann Engineering be liable for, travel, lodging, or any other expense incurred due to manufacturing defects in material and workmanship, or any other reason.
4. Any performance of repairs after the warranty coverage period has expired or performance of repairs regarding anything excluded from coverage after this limited warranty shall be considered good-will repairs and they will not alter the terms of this limited warranty, or extend any warranty coverage period.
5. Venue for any legal proceedings relating to or arising out of this warranty shall be in Tippecanoe County, Indiana, United States, which courts will have exclusive jurisdiction.

D. Local Law

1. This warranty gives the customer specific legal rights. The customer may also have other rights that vary from state to state in the United States or other countries.
2. To the extent that this warranty is inconsistent with local law, it shall be deemed modified, only to the extent necessary to be consistent with such local law.

This product uses FDA and/or NSF approved food grade materials anywhere the product touches the beverage.

Warning: This product contains or may contain chemical(s) known to the State of California to cause cancer, birth defects, or other reproductive harm.