

# 5 Gallon - 10 Gallon Gas Pilot System



## Assembly, Operation, & Maintenance

Congratulations on your purchase, and thank you for selecting the Gas Pilot System from Blichmann Engineering™ Pro Brewing. We are confident that it will provide you years of service and many gallons of outstanding beer. This manual will familiarize you with the use, assembly, and the sanitation procedures for the product.



## IMPORTANT INFORMATION

**PLEASE READ AND THOROUGHLY UNDERSTAND THIS MANUAL PRIOR TO USE FOR IMPORTANT SAFETY INFORMATION!**

**WARNING:** Sections labeled “Warning” can lead to serious injury or death if not followed. Please thoroughly read these sections and understand them completely before use. If you do not understand them or have any questions, contact your retailer or Blichmann Engineering ([www.BlichmannPro.com](http://www.BlichmannPro.com)) before use.

**CAUTION:** Sections labeled “Caution” can lead to equipment damage or unsatisfactory performance of the equipment. Please read these sections thoroughly. If you have any questions, contact your retailer or Blichmann Engineering ([www.BlichmannPro.com](http://www.BlichmannPro.com)) before use.

**IMPORTANT:** Sections labeled “Important” should specifically be followed to ensure satisfactory results with the product.

## REFER TO EACH INDIVIDUAL ITEM MANUAL FOR INSTALLATION INSTRUCTIONS

## What’s Included?

Item #	Part Name	Quantity
BE-001371-00	Gas Pilot Wort Manifold Assembly	1
BE-001372-01	Gas Pilot Controller Mount Assembly	1
AutoSparge	AutoSparge™	1
aWhirlpool-G2	Kettle Whirlpool Kit	1
aThruMometer-1/2	ThruMometer Assembly - 1/2"	1
QC-12ELBOW-01	QuickConnect™ 1/2" Elbow	9
QC-12STEM-01	QuickConnect™ 1/2" Stem	9
QC-38ELBOW-01	QuickConnect™ 3/8" Elbow	1
QC-12NUT-01	QuickConnect Nut	19
BE-000105-00	QuickConnect™ O-Ring	19
aQR-Chiller-Bkt-LTE	Quick Release Bracket for Therminator™	1
BE-000711-01	Needle Valve for Gas	3
BE-000163-00	1/2" Wide P-Clip	3
BE-000359-00	Silicone Tubing 3/4" OD	20 Feet
BE-000374-00	1/2" KwikClamps for ThruMometer™	2
BE-000001-00	Metal Oetiker Pinch Clamp	21
BE-001314-01	Burner Bracket A	6
BE-001315-00	Burner Bracket B	6
BE-000019-00	1/2" Hex Head Cap Screw	31

Item #	Part Name	Quantity
BE-000048-00	1/4" Flat Washer	25
BE-000029-00	1/4-20 Nut	66
BE-001379-00	5/8" Carriage Bolt	12
BE-001340-00	1" Carriage Bolt	3
BE-001338-00	1 3/4" Carriage Bolt	1
BE-001339-01	1 1/4" Hex Head Cap Screw	1
BE-000020-00	2 1/4" Hex Head Cap Screw	2
BE-001407-00	5/16" Washer Thick	1
BE-001337-00	5/8" Phillips Pan Head Screw	8
BE-001223-00	Marker Pad Zip Tie	10
BE-001334-00	Spiral Bundling Wrap	3 Feet
Zip Ties 8 inch	Zip Ties 8 inch	10
BE-001179-02	72" x 24" Gas Brewing Table	1
HE-002-03	Therminator™	1
aBrewCommander-G-C	Gas BrewCommander™ Controller	2
aRipTide-Pump	RipTide™ Pump	2
aHellFireBurner-FLR	HellFire™ Burner	3
	FalseBottom	1
	G2 BoilerMaker	3

## Tools Required

PTFE (Teflon) Thread Sealing Tape

Phillips Screwdriver

Flat-Head Screwdriver

7/16" Deep Well Socket/Ratchet

7/16" Open End Wrench

Adjustable Wrench

Bolt Cutters or Side/Diagonal Cutter

**Liquid Manifold Assembly**



**Controller Mount Assembly**



**Gas Manifold Assembly**



# TABLE ASSEMBLY

IMAGES BELOW REFLECT THE 1 BBL TABLE. YOUR TABLE WILL HAVE 4 LEGS.

**STEP 1:** Set the table top upside down on a carpet or blanket. **(Figure A)**

**NOTE:** Front of table can be determined by the Blichmann Engineering™ label, which is on the front.

**STEP 2:** Loosen all set screws on the table. Set the back legs in place. Leave the set screws loose. **(Figure B)**

**STEP 3:** Slide the 2 legs into the apron as shown in **Figure C**. Ensure the apron is being installed correctly. Double check the images below and on the next page.

**STEP 4:** Place the apron with the legs into the table. Leave the set screws loose. **(Figure D)**

**STEP 5:** Slide the shelf upside down onto the legs until the legs extend through the shelf brackets about 1 to 1 1/2 inches. At this point tighten **ALL** set screws in the table with the included allen wrench. **(Figure E)**

**STEP 6:** Once the set screws are tightened, its time to install the casters. The caster has a bolt running through it with a rubber outer casing. When the bolt is tightened the rubber will expand. Once the caster is placed into the leg, tighten the caster bolt to ensure its securely in place. **(Figure F)**

**STEP 7:** Flip the table over onto the casters. **(Figure G)**

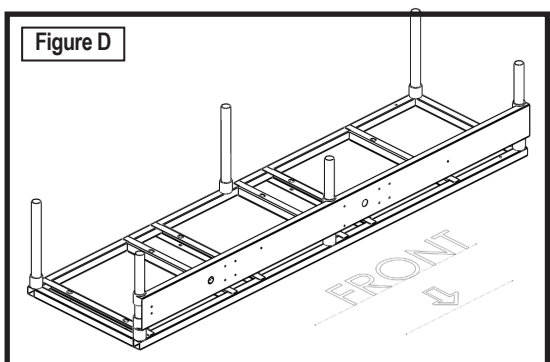
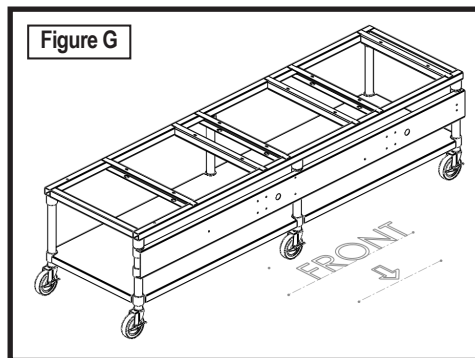
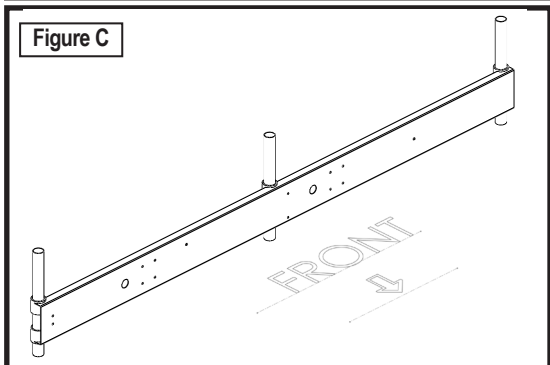
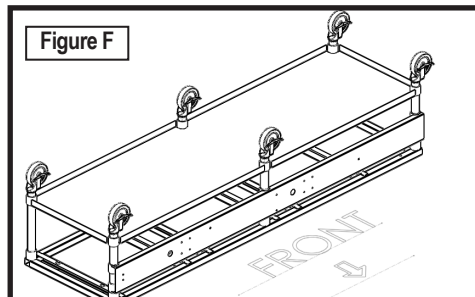
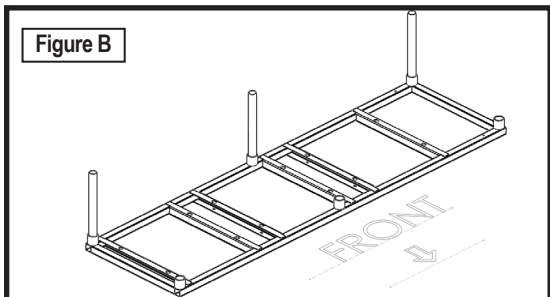
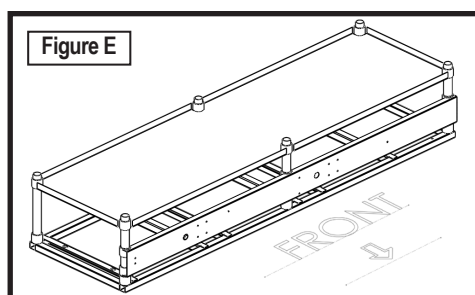
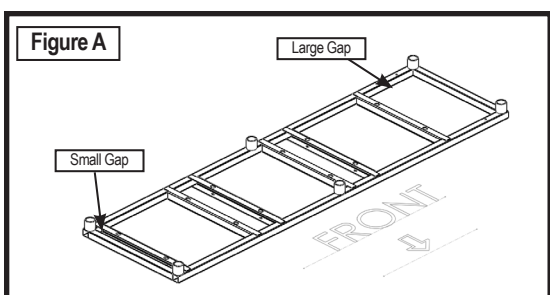

# BUILDING THE 5 AND 10 GALLON SYSTEMS

## Mounting the RipTide™ Pumps

Mount the RipTide™ to the apron on the holes shown below with the 1/4" x 1/2" Hex bolts (Bag 1), 1/4" flat washer (Bag 2), and close with a nut (Bag 3). **On the bottom left bolt of the left RipTide™ leave the hole empty (Shown below).** Once the RipTides™ are installed run the RipTide™ power cable through the grommet in the apron.

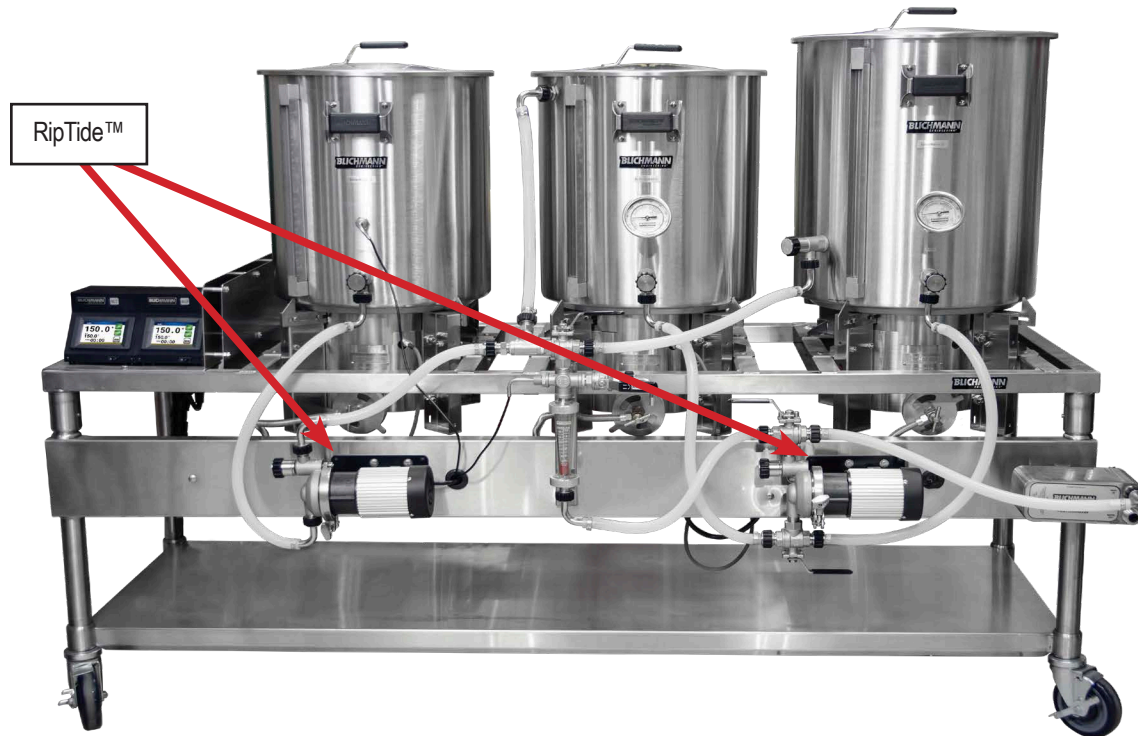
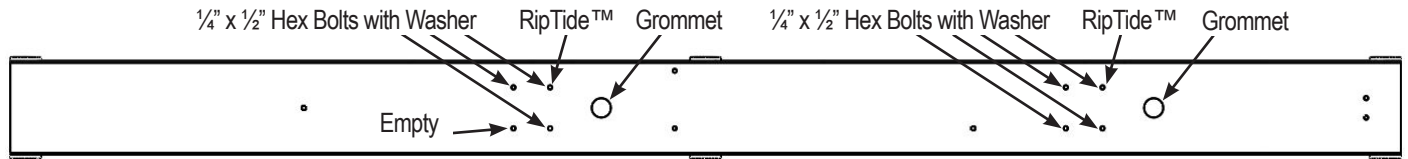

## Mounting the Gas Manifold

To mount the gas manifold to the backside of the apron use the 1/4" x 1" carriage bolt (Bag 4) through **Hole 1** then the p-clip on the gas manifold, through the 1/2" wide p-clip, and close with a washer (Bag 2) and nut (Bag 3) shown in **Figure 1**. Mount the other end of the gas manifold in the hole that was left empty in the left RipTide™ (**Hole 2**) with the 1/4" x 1 1/4" Hex Bolt (Bag 5), through the Washer (RipTide™ side) (Bag 2), through the p-clip on the gas manifold, through the 1/2" wide p-clip, and close with a washer (Bag 2) and nut (Bag 3) as shown in **Figure 2**. The p-clips on the topside of the gas manifold will be used for your cable management. Route the RipTide™ cables through the top p-clips.



**TIP:** Loosen the p-clips to allow more room for cables to fit together. Once all cables are in place tighten the p-clip.



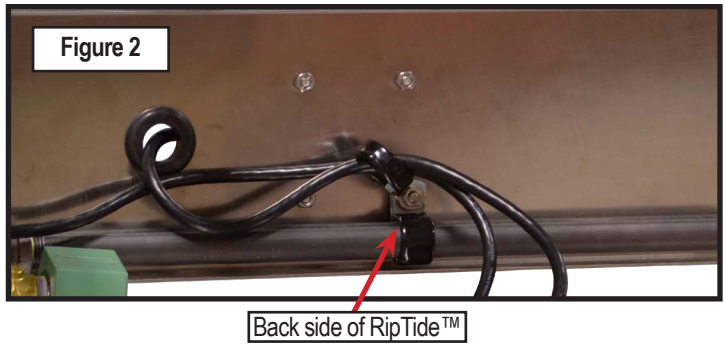
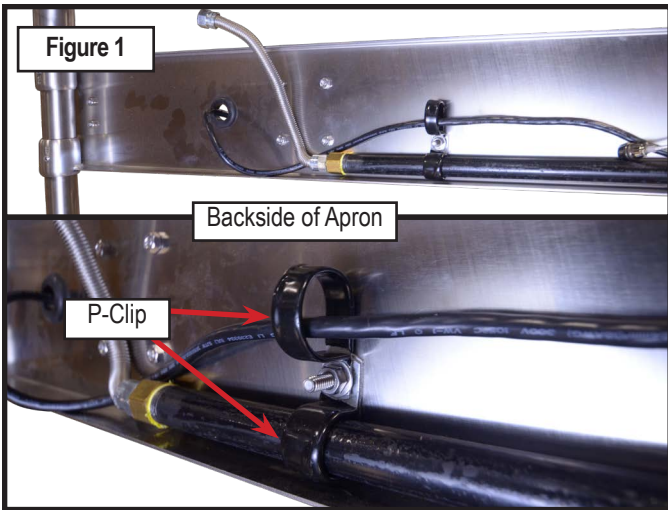

Place the 1/4" x 1" carriage bolt (Bag 4) through the hole shown below. On the inside of the apron on the same bolt use the 5/16" Washer Thick (Bag 5), then the 1/2" wide p-clip and close with a 1/4" flat washer (Bag 2) and nut (Bag 3).

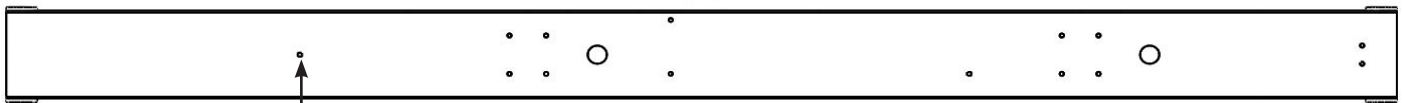

1/4" x 1" Carriage Bolt  
with 5/16" Washer Thick (inside)

Plug the solenoid cable and tighten the screw as shown in Figure 3.

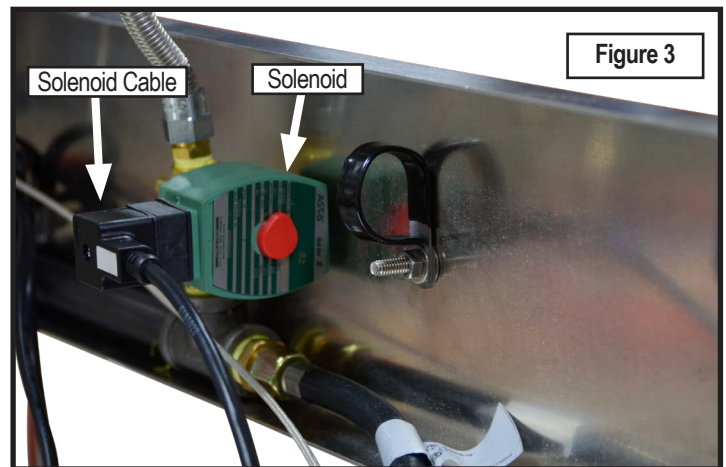

### Mounting the SparkBox™

Mount the 1/4-20 nuts on the apron studs with 1/2 inch exposed as shown in Figure 4. Mount the SparkBox™ to the studs and secure it with 1/4-20 nuts as shown in Figure 5.

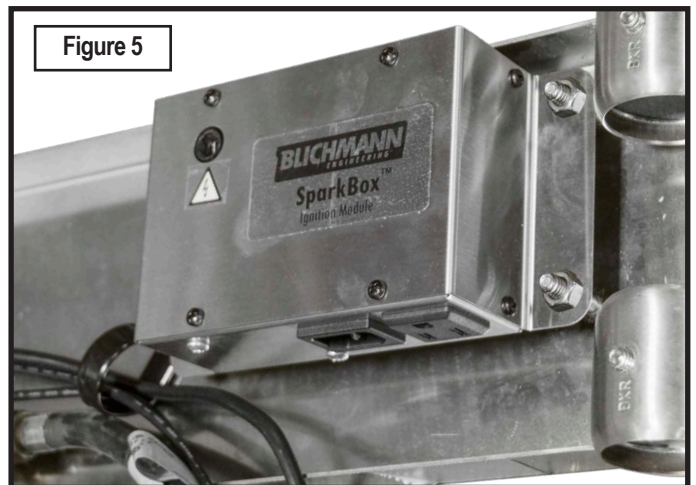

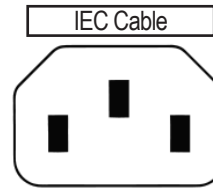
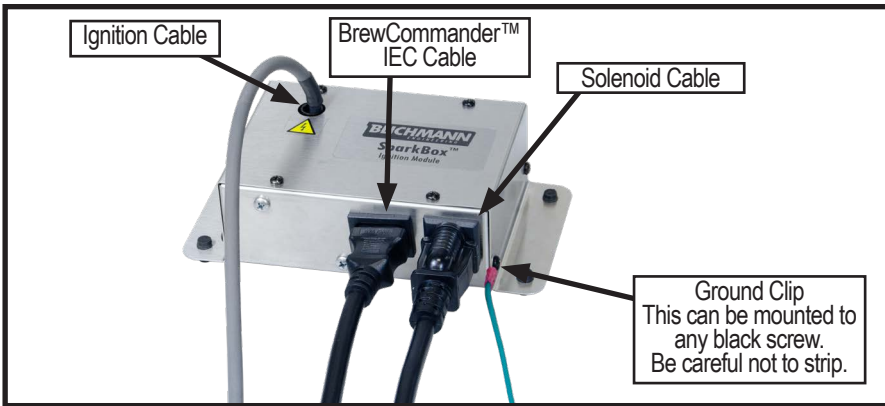

Connect the other end of the ignition cable to the ignition electrode that will be installed to the HellFire™ burner at a later step.



Mount the left SparkBox™ (from the back) over the cables and use the zipties to help with cable management as shown in Figure 6.

Mount the ground cable to the SparkBox™ and clip it onto the burner as shown in Figure 7.



## Installing Controller Mount Assembly

Install the Controller Mount Assembly to the left side of the table (Figure 8, Figure 9) with the 1/4" x 2-3/4" Hex Bolt (Bag 5) with a washer (Bag 2) and close with a washer (Bag 2) and nut (Bag 3).



Mount the 2 gas BrewCommander™ controllers to the Controller Mount Assembly (**Figure 9**) with the 10-24 x 5/8" Phillips Pan Head Screw (Bag 5) through the bottom of the assembly.

Run the RipTide™ power cables through the bottom of the controller mount assembly and plug the left RipTide™ into the left controller and the right RipTide™ into the right controller. Run the power cables from the controller through the hole in the controller mount assembly. Plug the power cables into the electrical box on the bottom side of the controller mount assembly. Run the female IEC cable through the controller mount assembly to be plugged into the SparkBox™ at a later step.

**TIP:** If fitting the cables through the grommet becomes difficult, remove the grommet and route the cables through the table and grommet one at a time, then reinstall the grommet.

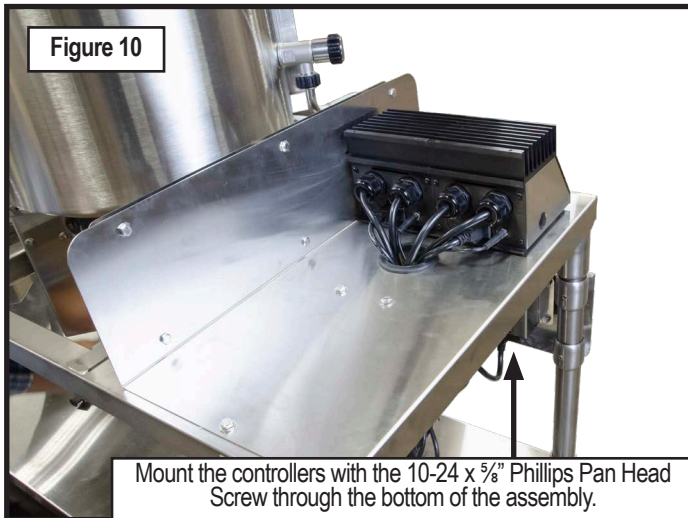

## Liquid Manifold

Attach the liquid manifold (pictured on page 3) to the apron with the 1/4" x 1" Carriage Bolt (Bag 4).

**NOTE:** If you're having trouble mounting the liquid manifold remove the flow meter to make it easier.

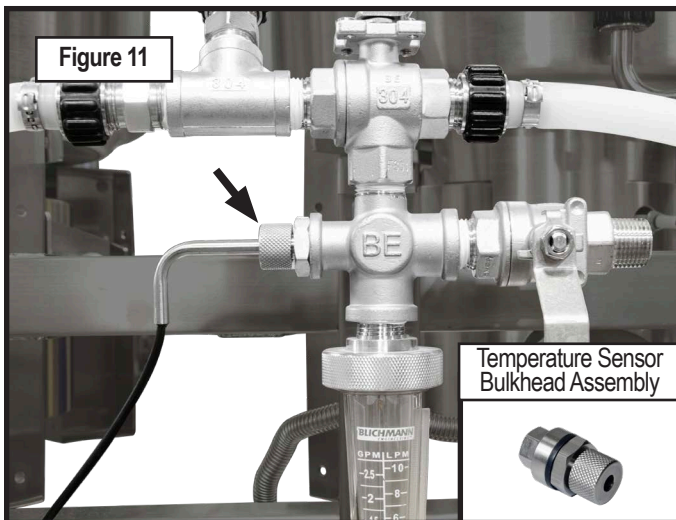
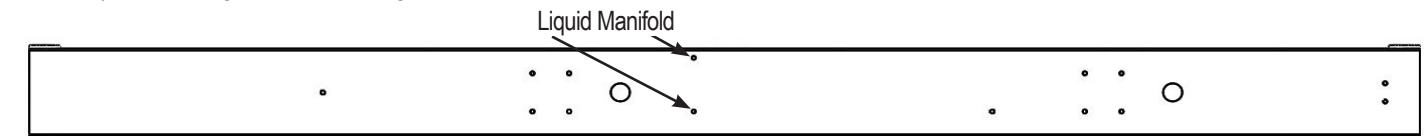

Mount a sensor to the liquid manifold as shown in **Figure 10**.

## Mounting the HellFire™ Burners

To mount the HellFire™ burners to the table you will need Burner Bracket A and Burner Bracket B. Attach the brackets as shown below with 1/4" x 1/2" Hex Bolt (Bag 1) and Nut (Bag 3). Torque to 150 in-lbs (12.5 ft-lbs).

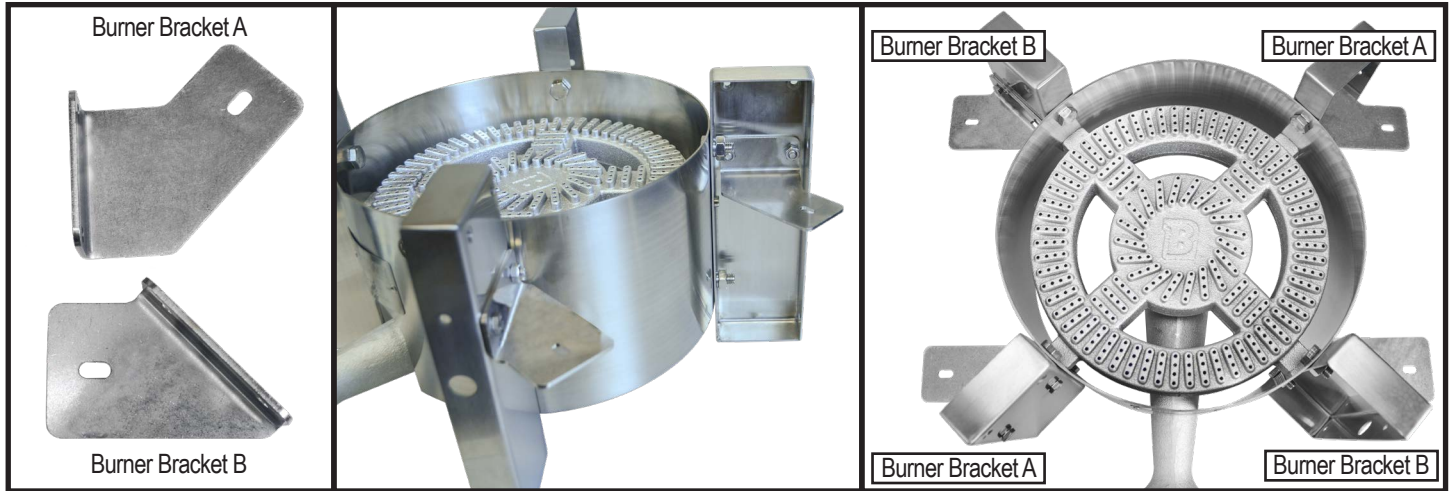

Mount the 3 HellFire™ burners to the table with the 1/4" x 5/8" Carriage Bolt (Bag 4) through the top and close with a washer (Bag 2) and nut (Bag 3) (**Figure 12**). Once the burners are mounted attach the needle valves to the HellFire™ burners (**Figure 13**). For HellFire™ assembly instructions refer to the HellFire™ manual. **ENSURE THE NEEDLE VALVES ARE TURNED OFF WHEN NOT IN USE.** For natural gas, see instructions included in the natural gas orifice manual.

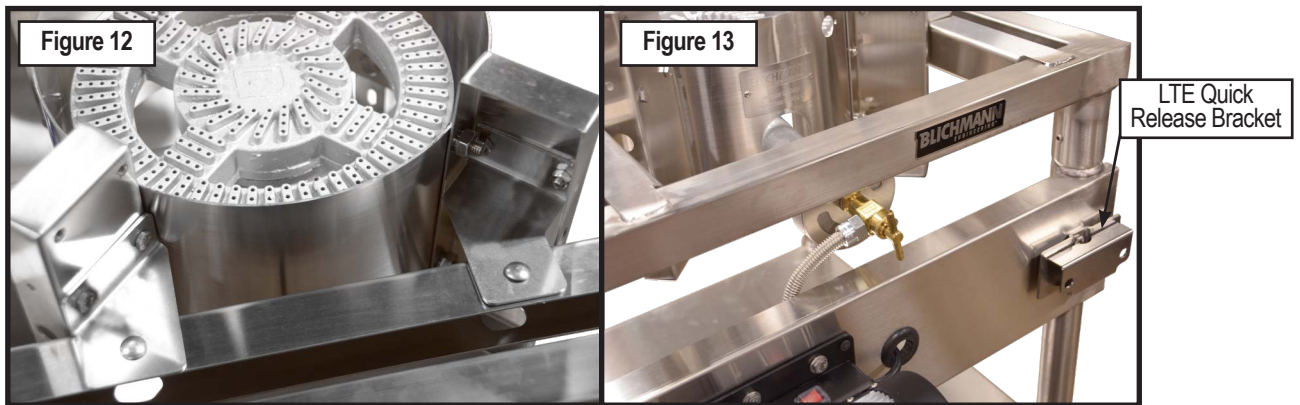

Mount the ignitor's to the left HellFire™ Burner and the middle HellFire™ Burner as shown in **Figure 14**. Mark the igniter at 1 1/2" and cut the igniter with bolt cutters or diagonal cutters as shown in **Figure 15**.

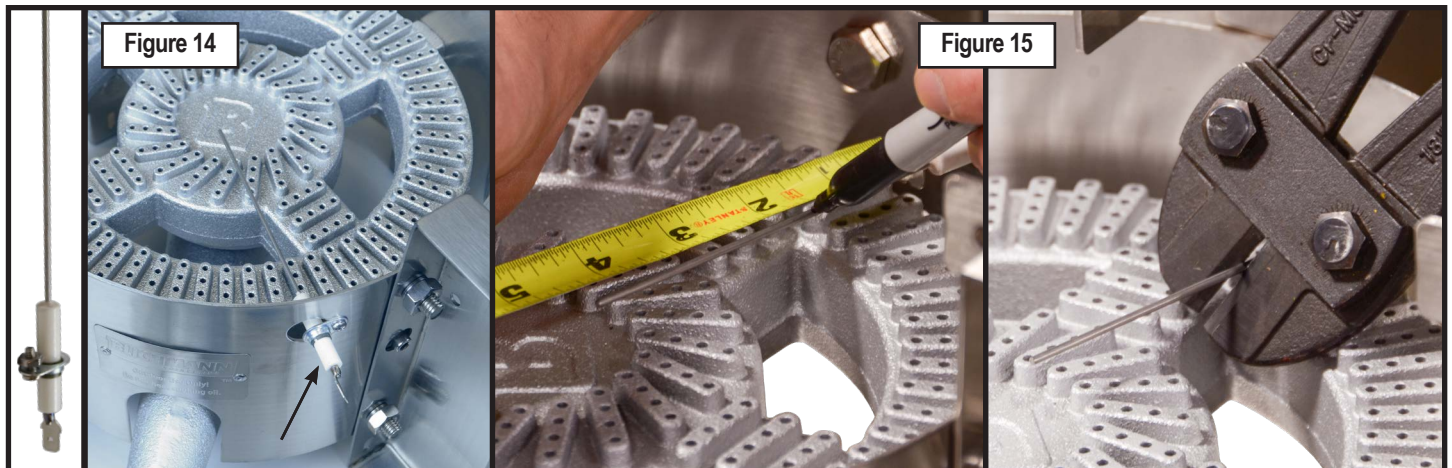

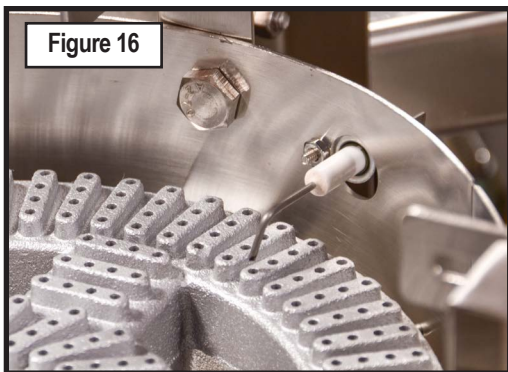

After the igniter is cut, bend the igniter so the tip is 3/16" to 1/4" from the burner casting and centered over a nozzle (Figure 16).

Use the Spiral Bundling Wrap to maintain all the cables. Bundle the cables together and wrap the Spiral Bundling Wrap around all the cables as shown in Figure 17.

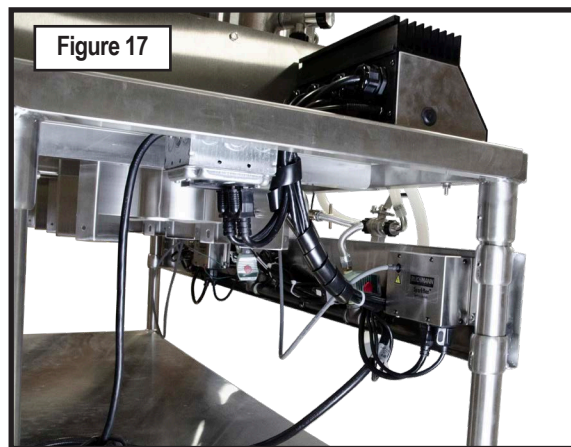

## Mounting the Therminator™

Attach the Therminator™ to the table apron using the LTE Quick Release Bracket shown in Figure 4.

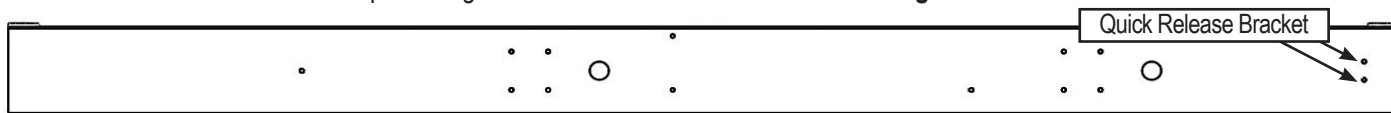

Place the kettles on the burners. Once kettles are in place, install the AutoSparge™, Temperature Sensor Bulkhead Assembly, and Whirlpool as shown in Figure 18. For instructions, refer to the individual product manuals.

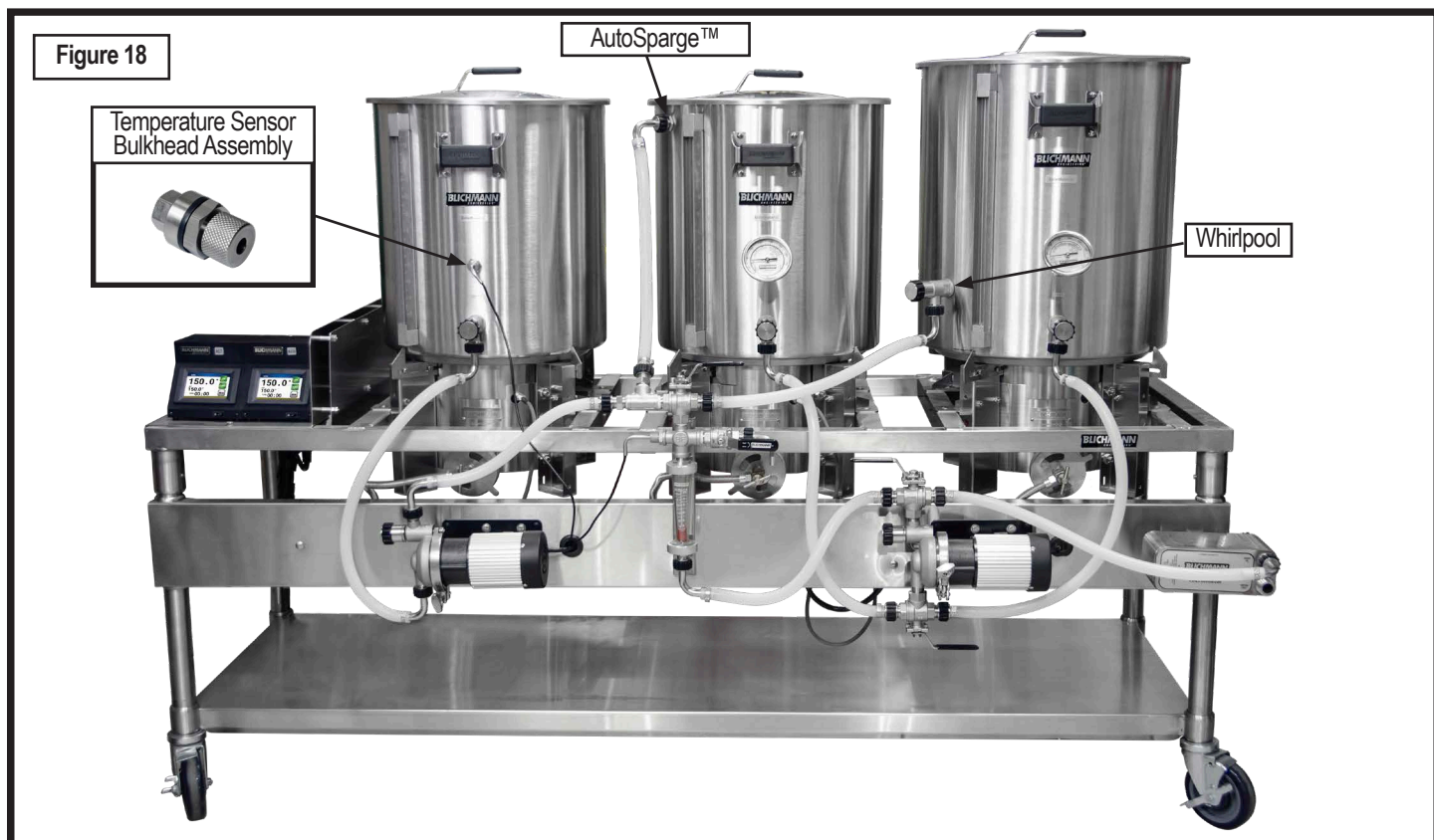

## Kettle Rims Hose Layout

Your parts kit will come with zip ties to label your hose. Use these to label the hoses on your system for easy re-assembly after cleaning. Below are the suggested labels and placement. Familiarize yourself with the function of the brewhouse. Attach QuickConnectors™ where needed. Your kit will come with 20 feet of hose. Attach the hose to the QuickConnectors™, stretch to the desired length, and cut. Once you are satisfied with the length and location of the hoses, crimp the hoses with a side cutter.

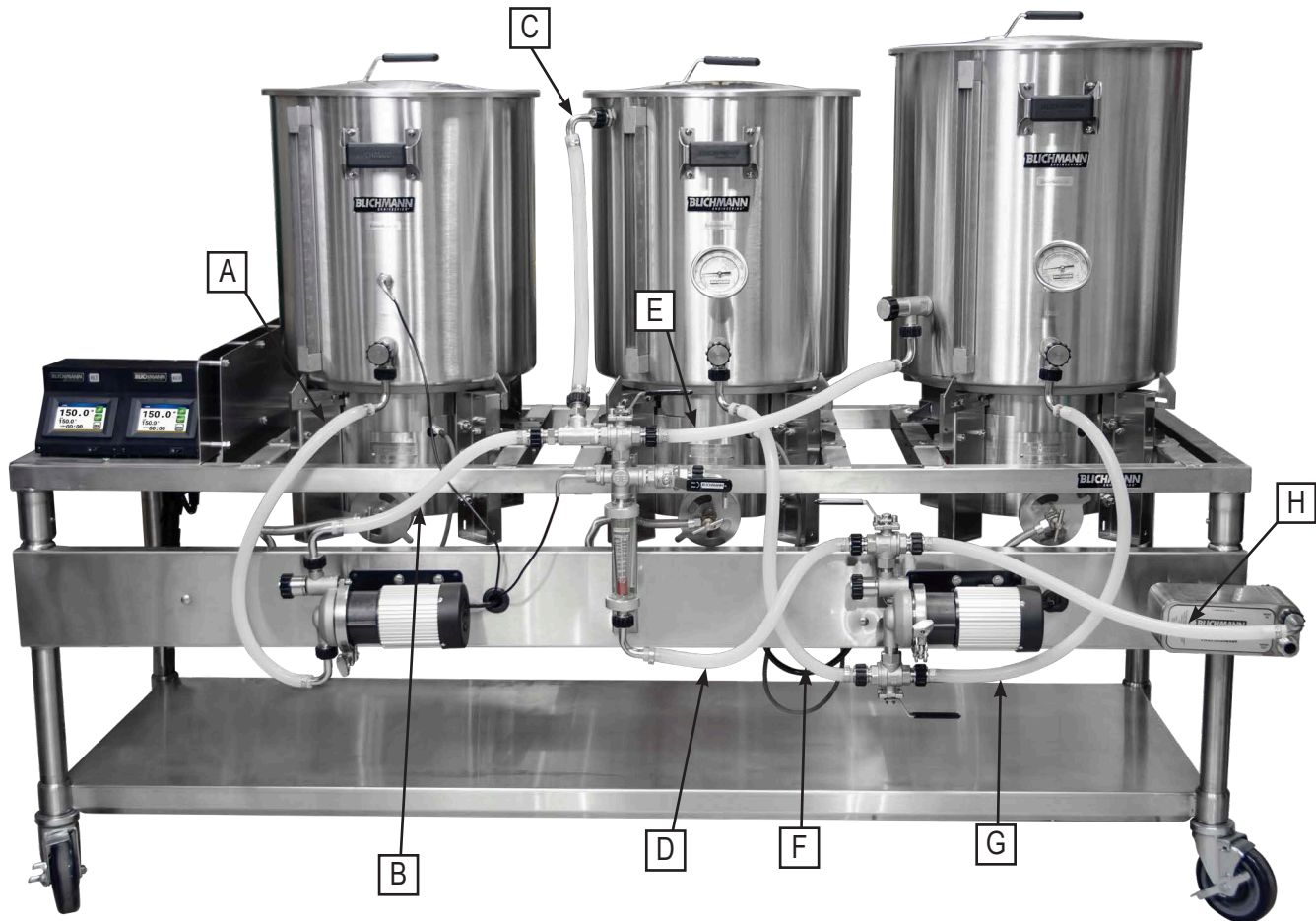

HOSE	QUICKCONNECT™ STRAIGHT	QUICKCONNECT™ ELBOW	LOCATION
A		XX	HLT to left pump inlet
B	X	X	Left pump outlet to tee
C	X	X	Tee to AutoSparge™
D	X	X	Right pump outlet to flow meter
E	X	X	Three way valve to boil kettle whirlpool
F	X	X	Mash to right pump inlet
G	X	X	Boil kettle valve to right pump inlet
H	X	X	Right pump outlet to Thermanator™

# HERMS Coil System Layout

Place the kettles on the burners. Install the HERMS coil in the HLT as shown in **Figure 19**. Install the AutoSparge™ in the location shown in **Figure 19**. Install the Whirlpools in the locations shown in **Figure 19**.

Install the 3-way valve on the left RipTide™ as shown in **Figure 19** with Teflon tape.

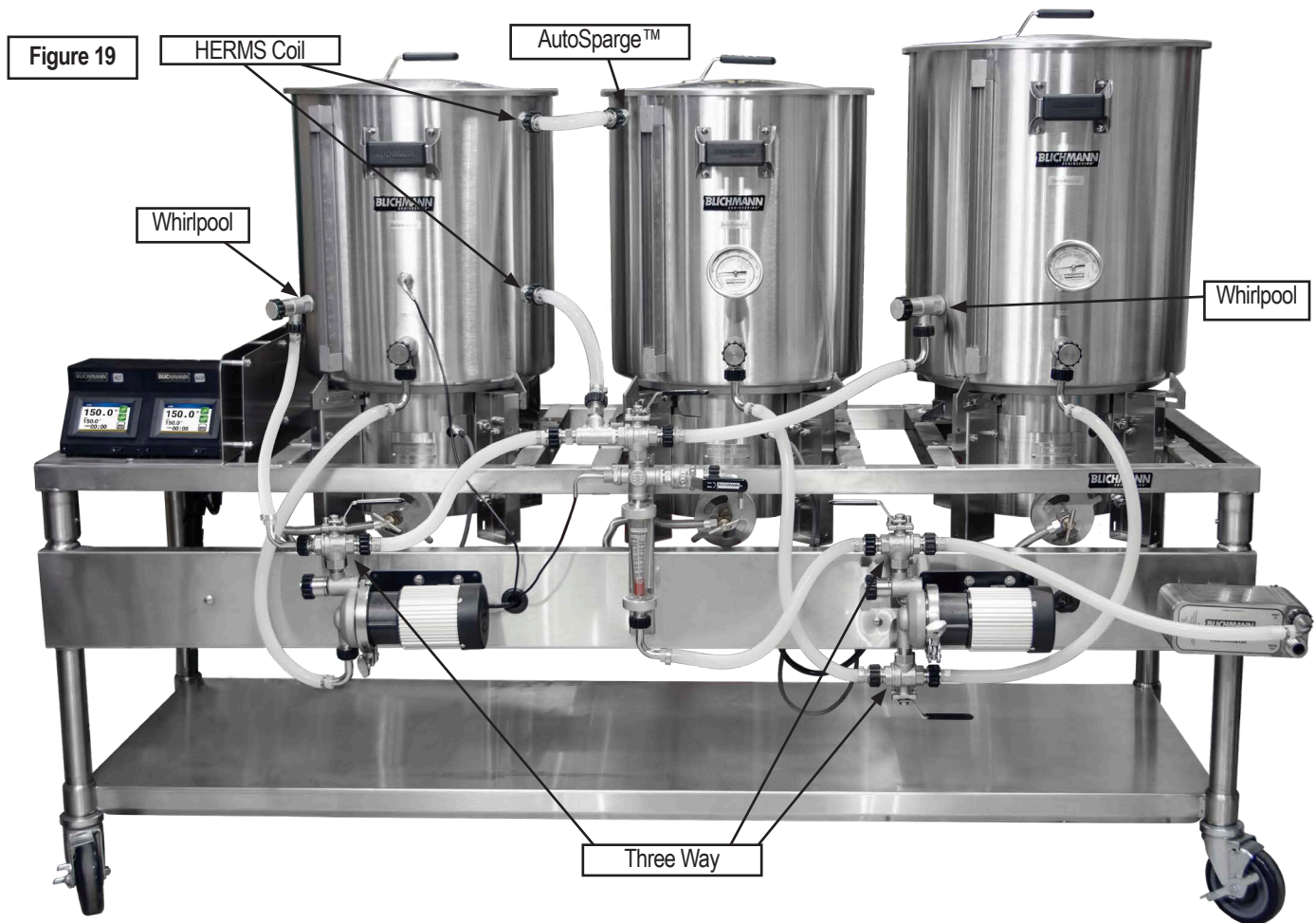

## HERMS Hose Layout

Your parts kit will come with zip ties to label your hose. Use these to label the hoses on your system for easy re-assembly after cleaning. Below are the suggested labels and placement. Familiarize yourself with the function of the brewhouse. Attach QuickConnectors™ where needed. Your kit will come with 20 feet of hose. Attach the hose to the QuickConnectors™, stretch to the desired length, and cut. Once you are satisfied with the length and location of the hoses, crimp the hoses with a crimping tool.

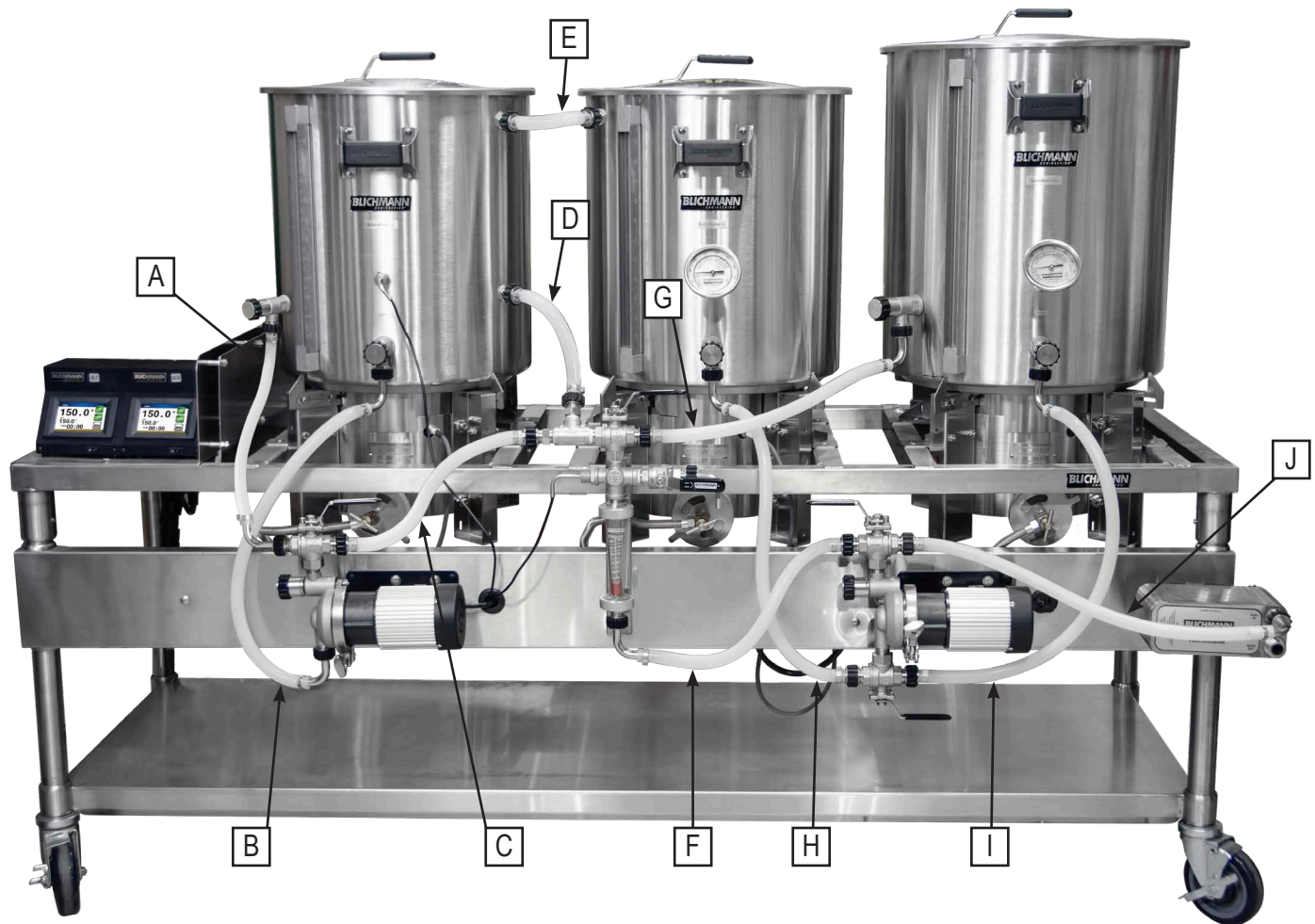

HOSE	QUICKCONNECT™ STRAIGHT	QUICKCONNECT™ ELBOW	LOCATION
A	X	X	HLT whirlpool to three way valve on left pump outlet
B		XX	HLT to left pump inlet
C	XX		Three way valve on left pump outlet to tee
D	XX		Tee to HERMS inlet
E	XX		HERMS outlet to AutoSparge™
F	X	X	Right pump outlet to flow meter
G	X	X	Three way valve on liquid manifold to whirlpool in boil kettle
H	X	X	Mash to right pump inlet
I	X	X	Boil kettle valve to right pump inlet
J	X	X	Right pump outlet to Therminator™

## OPERATION: Kettle RIMS

Now that you've completed installation. We recommend doing a mock brewday with water to familiarize yourself with the functionality of the system. This is also a good time to check all hoses and connections for leaks. Remember during testing you can refer to any individual components manuals for an in depth explanation of the products operation.



## Connecting Hoses

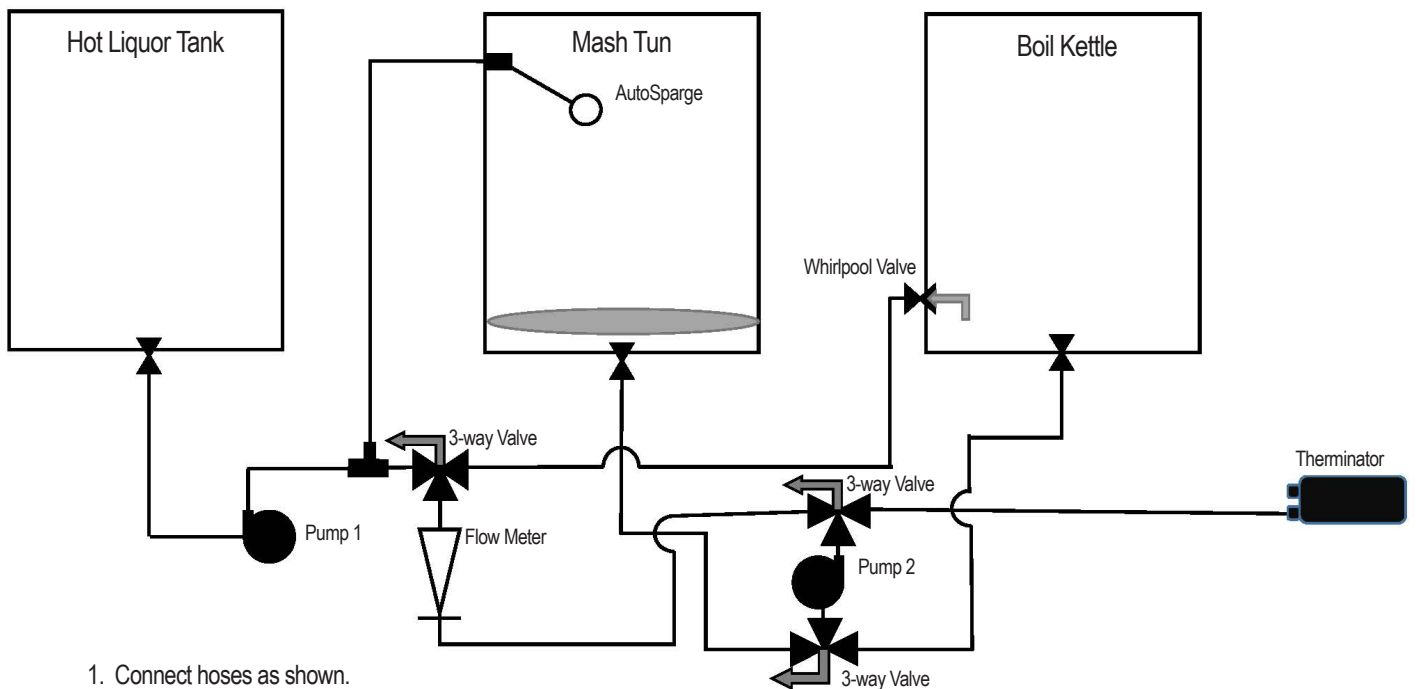

## Heating Strike Water

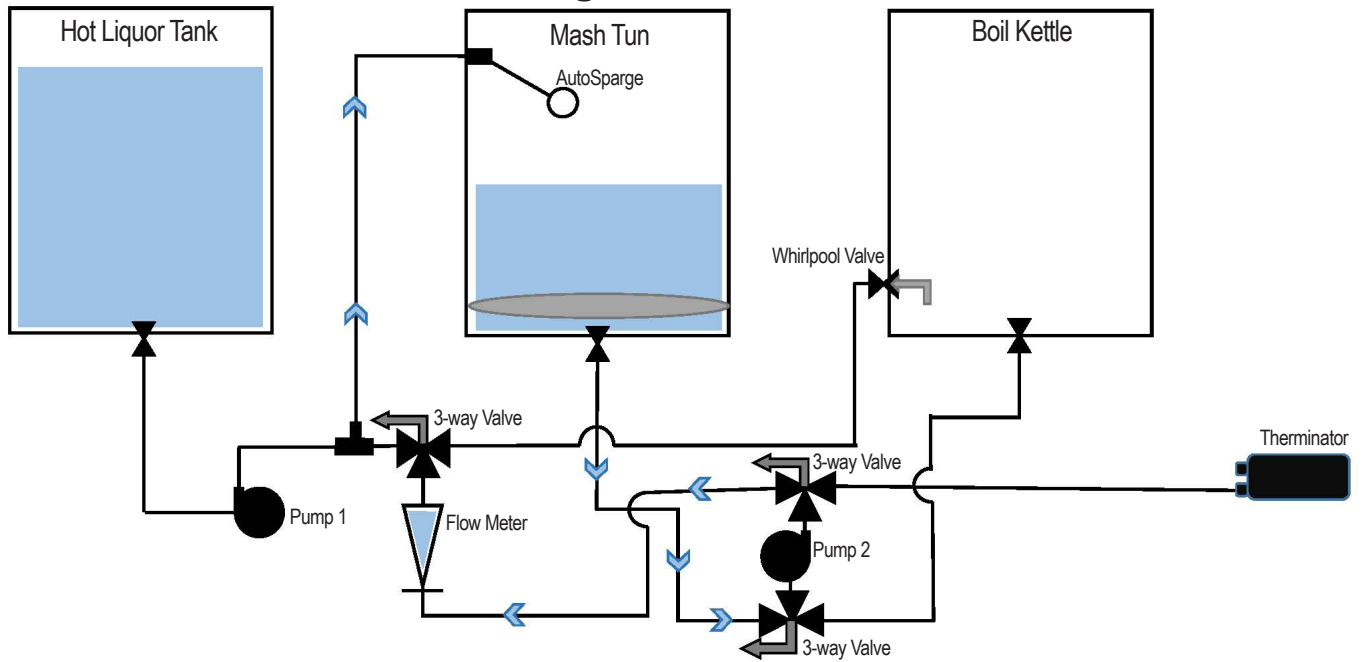

1. Set the Hot Liquor Tank to Auto at the desired temperature (See BrewCommander™ Manual)
2. Set Pump 2 to ON and direct the flow as shown for recirculation through the liquid manifold.
3. Set the Mash controller to the desired strike water temperature and set the control switch to AUTO.

## Mash

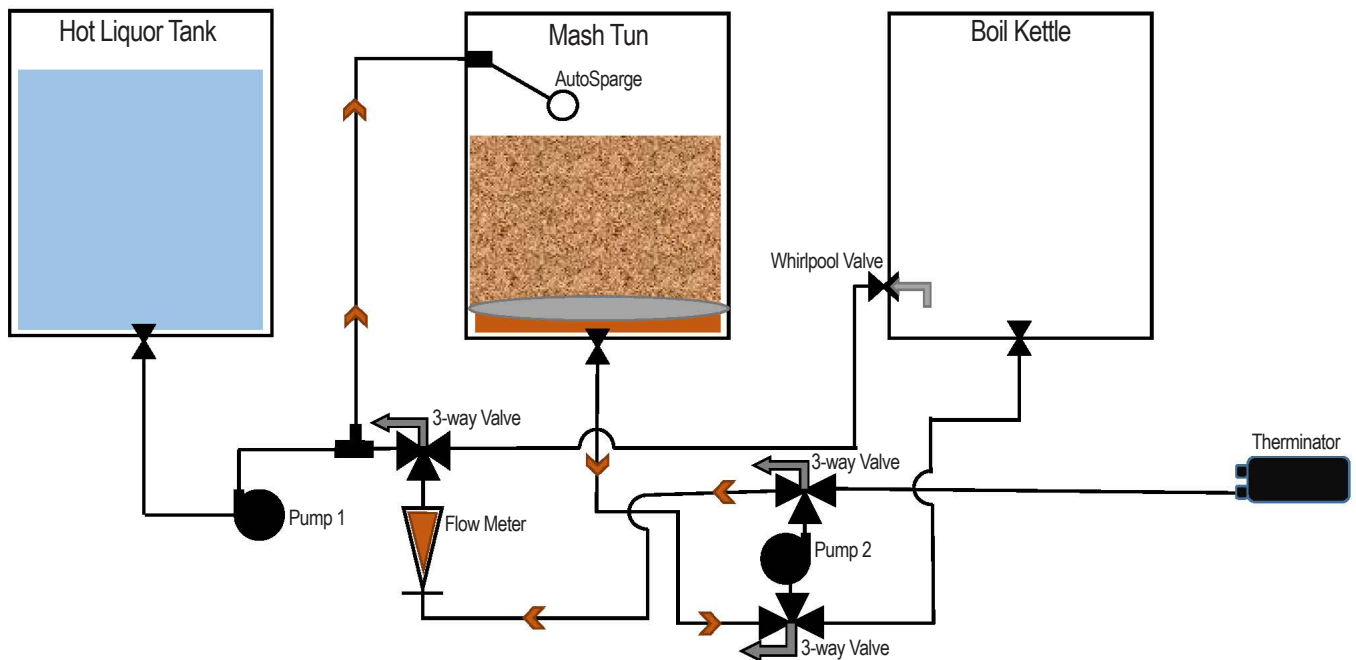

1. Once the strike water is at the desired temp, turn controller to Reset (off). Set Pump 2 to OFF and add the grain to the Mash Tun. (Dough in)
2. After 10 minutes of rest, set Pump 2 to ON and adjust the valve to set the appropriate flow rate. (see BoilerMaker Manual)
3. Set the MashTun controller to the desired mash temperature and follow step mashing techniques.

## Sparge and Transfer

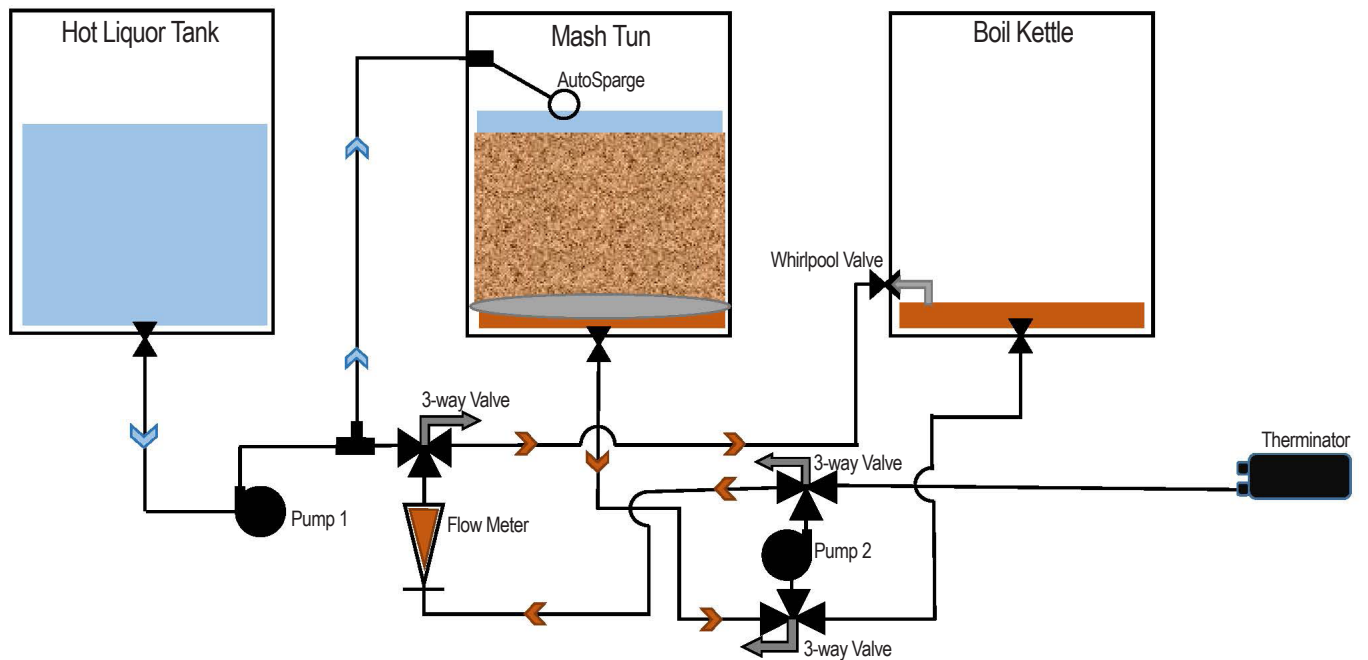

1. Turn the valve on the liquid manifold towards the Boil Kettle.
2. Turn on pump 1 and set the appropriate level on the AutoSparge (Refer to AutoSparge Manual).
3. Turn on pump 2 and begin transferring to the boil kettle.
4. Set the Hot Liquor Tank burner controller to off when the level falls close to the temperature probe.
5. The boil kettle burner can be lit as soon as liquid covers the entire bottom of the kettle.
6. Once a desired pre-boil volume is reached in the boil kettle, turn off both pumps, and close the output valves.

## Boil

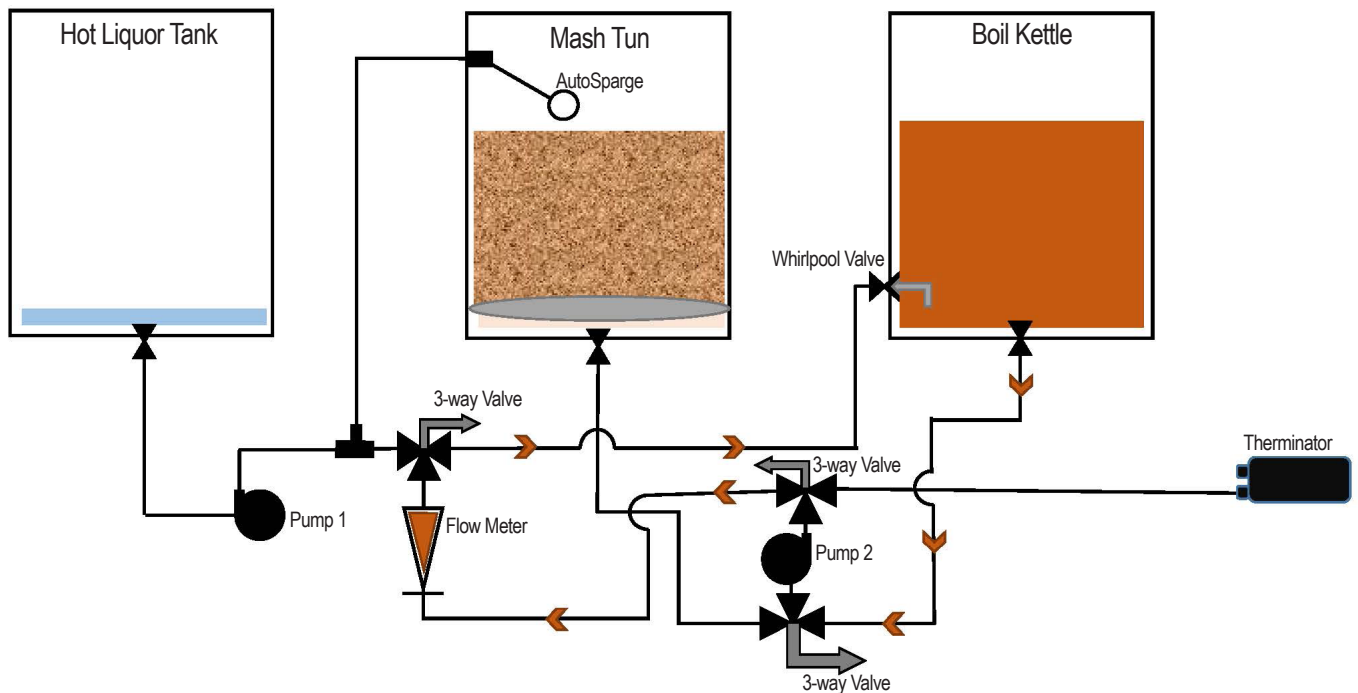

1. Bring wort to boil and add additions as required.
2. At the end of the boil, set the valves to the position shown above and turn on Pump 2 to Whirlpool for about 10 minutes. Let the Wort settle for 10 to 15 minutes at the end of the whirlpool.

# Chill

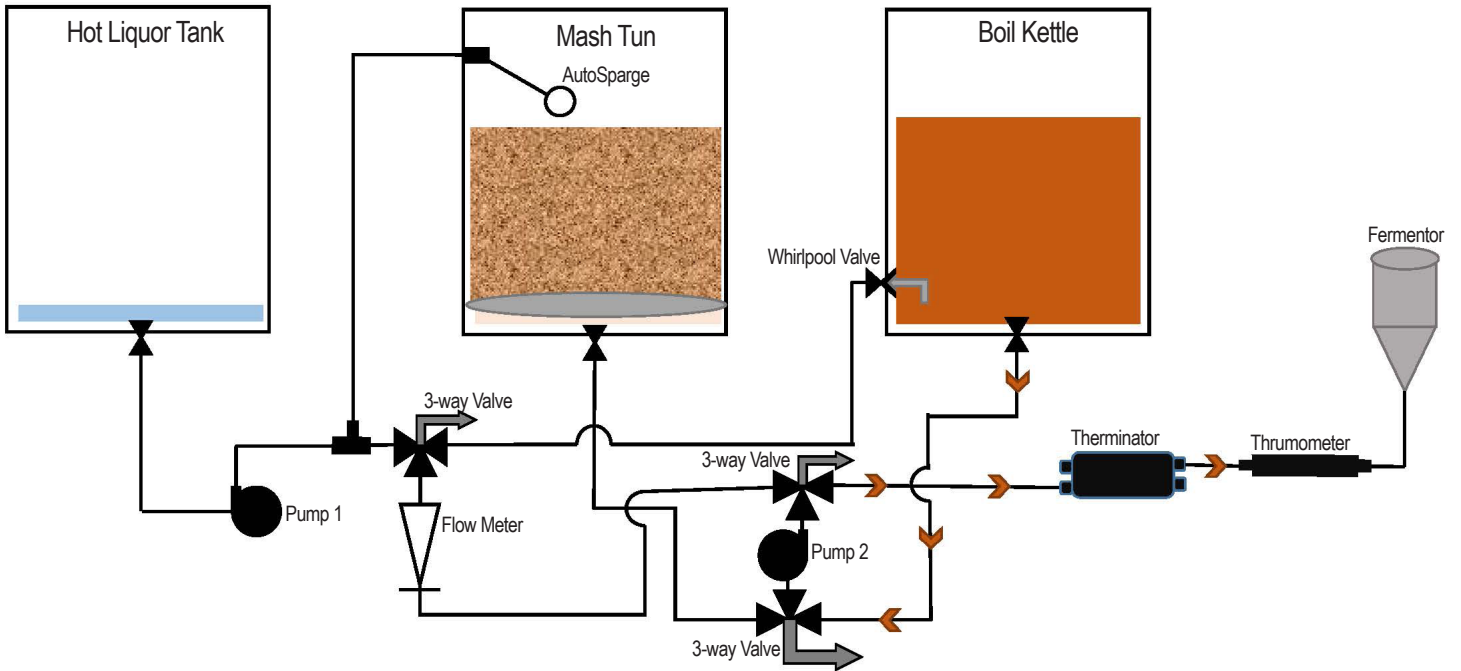

1. Connect hose as shown for chilling.
2. Rotate the dip tube on the Boil Kettle for clearer results. See the BoilerMaker Instruction Manual if not set up to rotate.
3. Turn on cold water supply and begin pumping wort through the heat exchanger.
4. Monitor the temperature on the ThruMometer™ and adjust flow as required. Decrease the wort flow to lower the temperature or decrease water flow to increase the temperature. (see the Thermanator™ Instruction Manual.)

# OPERATION: HERMS



## Connecting Hoses

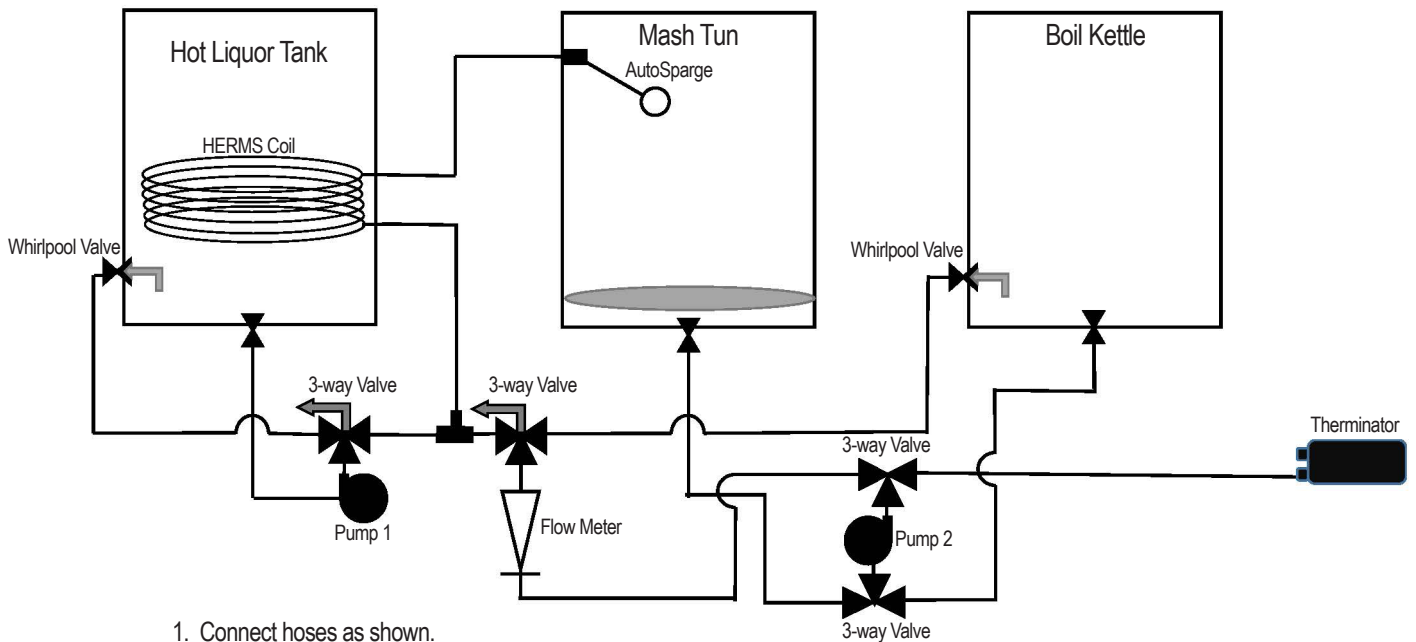

1. Connect hoses as shown.

## Heating Strike Water

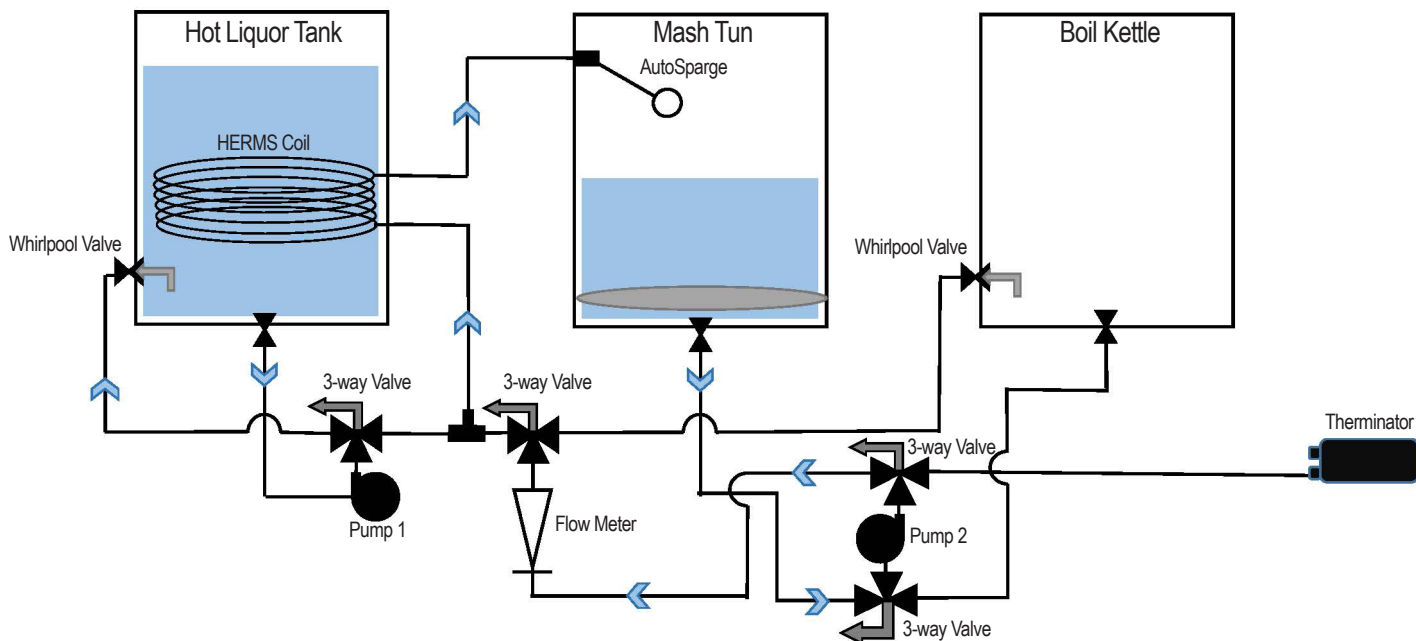

1. Set the Hot Liquor Tank to Auto at about 3 degrees above the desired strike water temperature. (See BrewCommander™ Manual) Additional heat can be added with the middle burner set to auto at the desired strike water temperature.
2. Set both pumps to ON and direct the flow as shown for dual recirculation.
3. The right controller reads the temperature at the Liquid Manifold and the left controller will control the HLT Temperature

## Mash

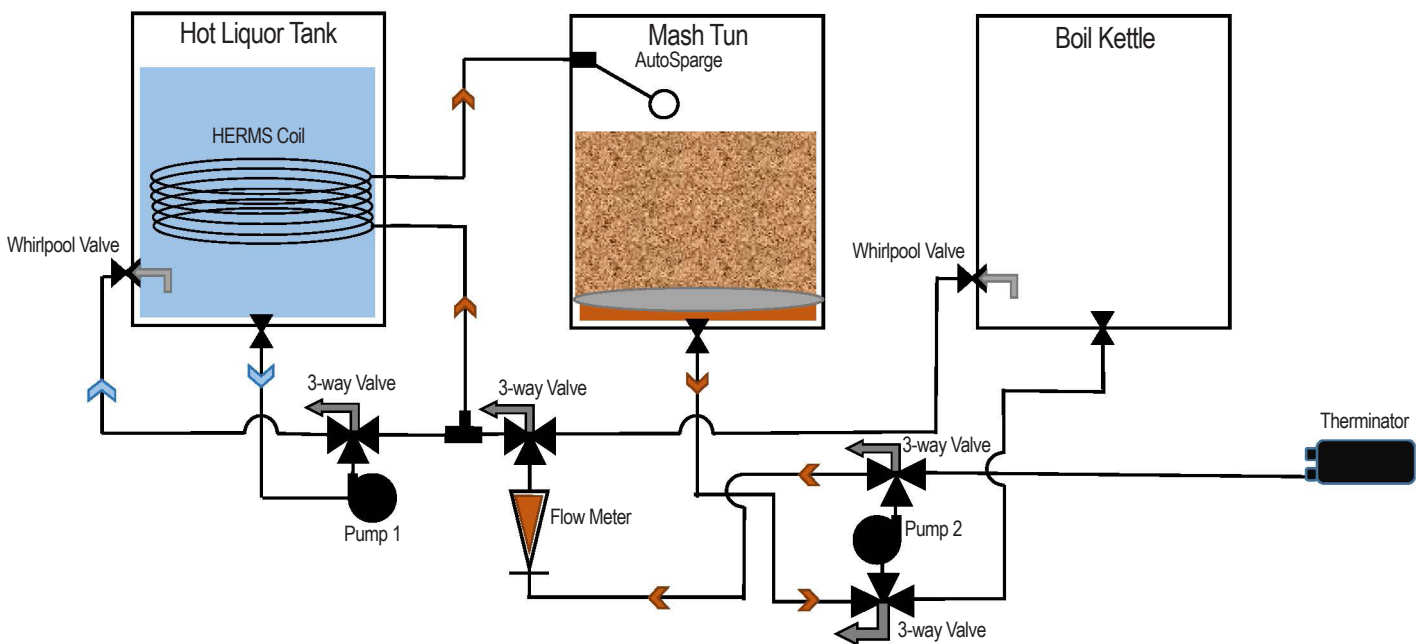

1. Once the strike water is at the desired temp, turn off pump 2. Set the mash tun controller to the off power mode and add the grain to the Mash Tun. (Dough in)
2. Adjust the set point on the hot liquor tank 3 degrees above the desired mash temperature and set the controller to AUTO mode. Continue to recirculate with Pump one.
3. After 10 minutes of rest, turn on Pump 2 and adjust the valve to set the appropriate flow rate. (see BoilerMaker Manual)
4. Determine the correct temperature of the HLT to achieve favorable mash temperature. Document your findings for future use. Perform desired step mashing techniques as required.

## Sparge and Transfer

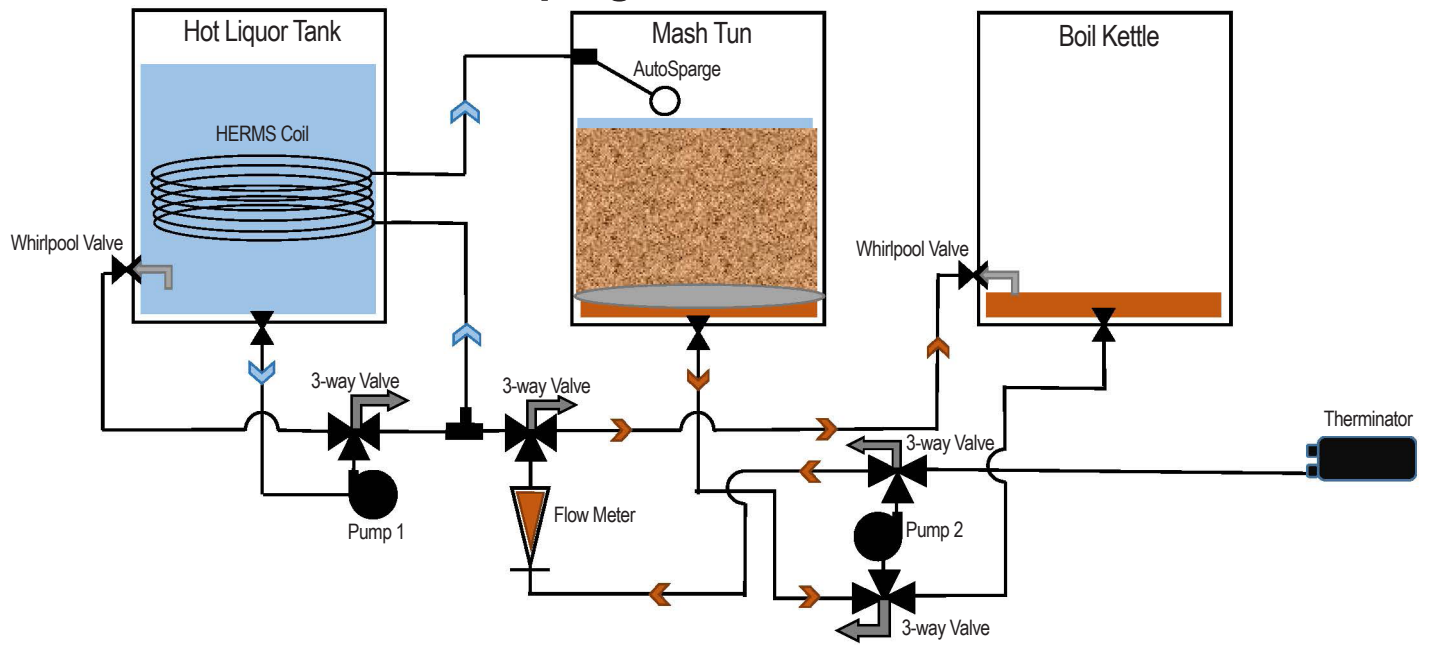

1. Turn the valve on the liquid manifold towards the Boil Kettle.
2. Redirect the flow of Pump 1 to the Right and set the appropriate level on the AutoSparge (Refer to AutoSparge Manual).
3. Turn on pump 2 and begin transferring to the boil kettle.
4. Set the Hot Liquor Tank burner controller to off when the level falls close to the temperature probe.
5. The boil kettle burner can be lit as soon as liquid covers the bottom of the kettle.
6. Once a desired pre-boil volume is reached in the boil kettle, turn off both pumps, and close the output valves.

## Boil

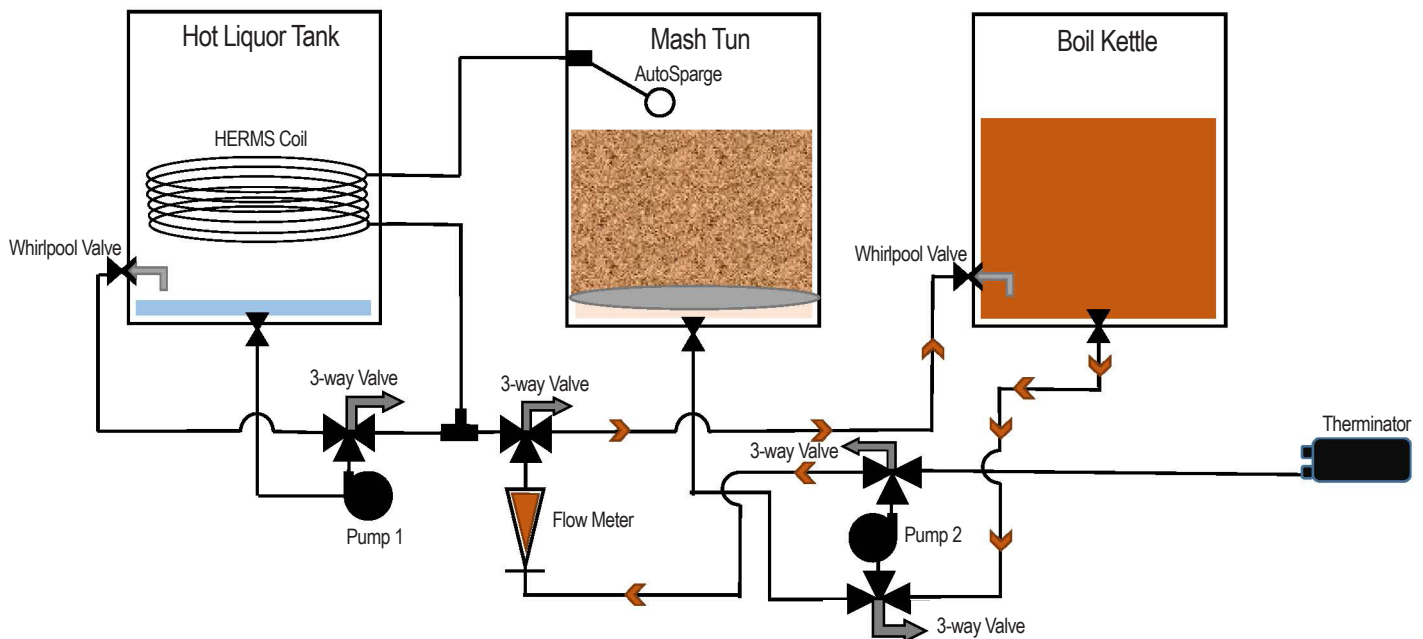

1. Bring wort to boil and add additions as required.
2. At the end of the boil, set the valves to the position shown above and turn on Pump 2 to Whirlpool for about 10 minutes. Let the Wort settle for 10 to 15 minutes at the end of the whirlpool.

# Chill

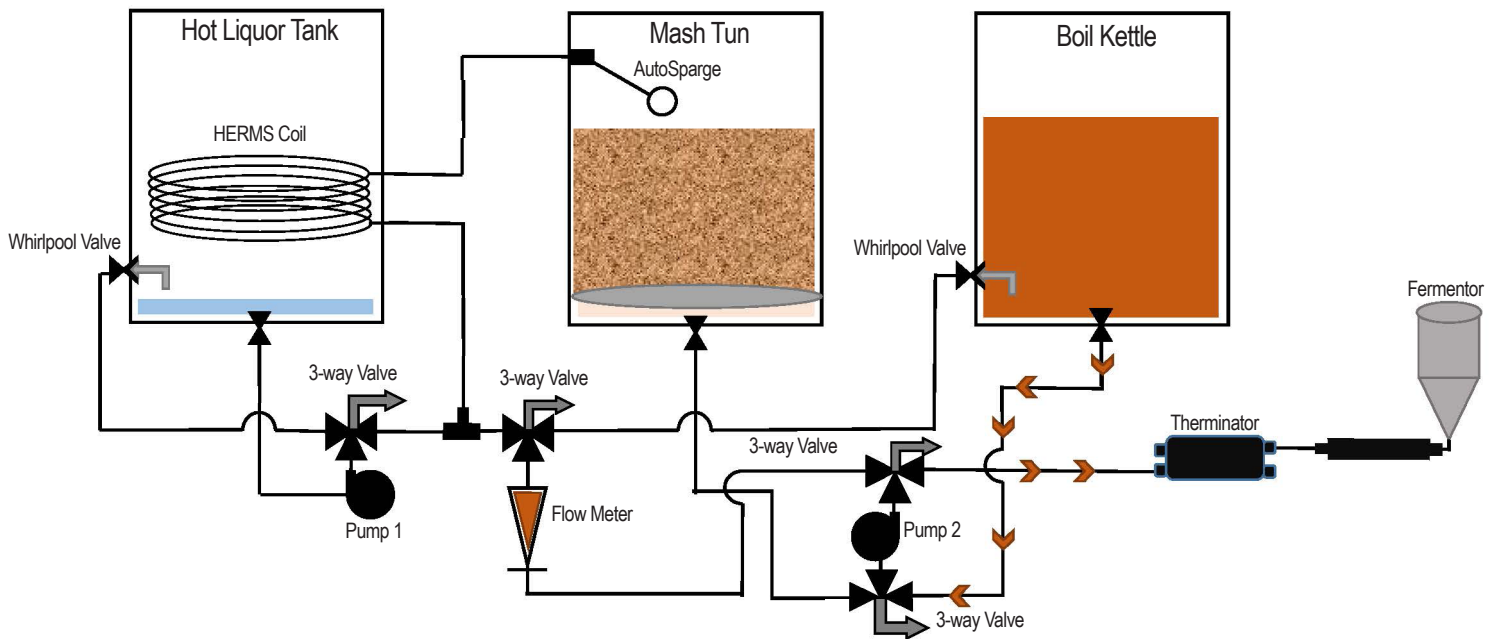

1. Connect hose as shown for chilling.
2. Rotate the dip tube on the Boil Kettle for clearer results. See the BoilerMaker Instruction Manual if not set up to rotate.
3. Turn on cold water supply and begin pumping wort through the heat exchanger.
4. Monitor the temperature on the ThruMometer and adjust flow as required. Decrease wort flow to lower the temperature or decrease water flow to increase the temperature.

## Blichmann Engineering™ Product Warranty

### A. Limited Warranty

1. Blichmann Engineering warrants to the original purchaser that this product will be free from manufacturing defects in material and workmanship for a period of one (1) year from the date of purchase by the customer. Proof of purchase is required. Blichmann Engineering's obligation to repair or replace defective materials or workmanship is the sole obligation of Blichmann Engineering under this limited warranty.
2. This product is for home use only. The limited warranty covers only those defects that arise as a result of normal use of the product and does not cover any other problems, including, but not limited to, those that arise as a result of:
  - a. Improper maintenance or modification;
  - b. Damage due to incorrect voltage or improper wiring by customer;
  - c. Operation outside of the product's specifications;
  - d. Carelessness or neglect to operate the product in accordance with instructions provided with the product;
  - e. Damaging the tamper label on the product;
  - f. Damage by over-tightening the fasteners;
  - g. Failure to follow cleaning and / or maintenance procedures; or
  - h. Exceeding published operational temperatures.
3. Blichmann Engineering reserves the right to request delivery of the defective component for inspection before processing the warranty claim. If Blichmann Engineering receives, during the applicable warranty period, notice of a defect in any component that is covered by the warranty, Blichmann Engineering shall either repair or replace the defective component with a new or rebuilt component at Blichmann Engineering's option.
4. Blichmann Engineering must be notified within seven (7) days of the delivery date of any shipping damage. Customer is responsible for shipping damage outside of this time period. Approval for return must be provided by Blichmann Engineering prior to any return. Customer is responsible for keeping all original packaging material for warranty returns. Blichmann Engineering is not responsible for damage from improperly packaged warranty returns, and these repair costs will be the sole responsibility of the customer. Shipping costs for warrantee returns are covered only for the contiguous United States.
5. Blichmann Engineering's limited warranty is valid in any country where the product is distributed.

### B. Limitations of Warranty

1. Any implied warranty that is found to arise by way of state or federal law, including any implied warranty of merchantability or any implied warranty of fitness, is limited in duration to the terms of this limited warranty and is limited in scope of coverage to this warranty. Blichmann Engineering disclaims any express or implied warranty, including any implied warranty of fitness for a particular purpose or merchantability, on items excluded from coverage as set forth in this limited warranty.
2. Blichmann Engineering makes no warranty of any nature beyond that contained in this limited warranty. No one has authority to enlarge, amend, or modify this limited warranty, and Blichmann Engineering does not authorize anyone to create any other obligation for it regarding this product.
3. Blichmann Engineering is not responsible for any representation, promise, or warranty made by any independent dealer or other person beyond what is expressly stated in this limited warranty. Any selling or servicing dealer is not Blichmann Engineering's agent, but an independent entity.

### C. Limitations of Liability

1. The remedies provided in this warranty are the customer's sole and exclusive remedies.
2. Except for the obligations specifically set forth in this warranty, in no event shall Blichmann Engineering be liable for direct, indirect, special, incidental, or consequential damages, whether based on contract, tort, or any other legal theory and whether or not advised of the possibility of such damages.
3. This warranty does not cover, and in no event shall Blichmann Engineering be liable for, travel, lodging, or any other expense incurred due to manufacturing defects in material and workmanship, or any other reason.
4. Any performance of repairs after the warranty coverage period has expired or performance of repairs regarding anything excluded from coverage after this limited warranty shall be considered good-will repairs and they will not alter the terms of this limited warranty, or extend any warranty coverage period.
5. Venue for any legal proceedings relating to or arising out of this warranty shall be in Tippecanoe County, Indiana, United States, which courts will have exclusive jurisdiction.

### D. Local Law

1. This warranty gives the customer specific legal rights. The customer may also have other rights that vary from state to state in the United States or other countries.
2. To the extent that this warranty is inconsistent with local law, it shall be deemed modified, only to the extent necessary to be consistent with such local law.

This product uses FDA and/or NSF approved food grade materials anywhere the product touches the beverage.  
Warning: This product contains or may contain chemical(s) known to the State of California to cause cancer, birth defects, or other reproductive harm.