



BREWING EQUIPMENT®

CRUCIBLE™

ASSEMBLY & MAINTENANCE MANUAL

**** PLEASE READ THOROUGHLY PRIOR TO USE FOR IMPORTANT SAFETY INFORMATION****

WARNING: Sections labeled "Warning" can lead to serious injury or death if not followed. Please thoroughly read these sections and understand them completely before use. If you do not understand them or have any questions, contact your retailer or Anvil Brewing Equipment (www.anvilbrewing.com) before use.

CAUTION: Sections labeled "Caution" can lead to equipment damage or unsatisfactory performance of the equipment. Please read these sections thoroughly. If you have any questions, contact your retailer or Anvil Brewing Equipment (www.anvilbrewing.com) before use.

IMPORTANT: Sections labeled "Important" should specifically be followed to ensure satisfactory results with the product.

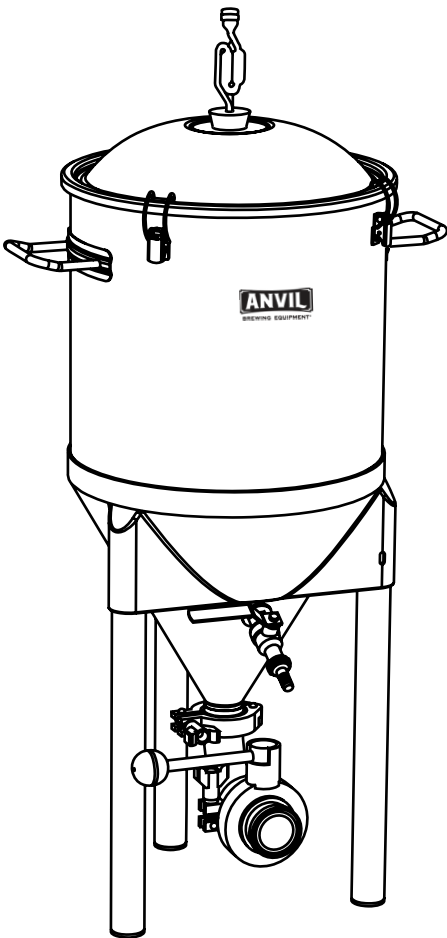

Description	Quantity
1-1/2" Tri-Clamp Butterfly Valve	1
1-1/2" Tri-Clamp Gasket	2
1-1/2" Tri-Clamp	2
1-1/2" Tri-Clamp Elbow	1
Straight Ball Valve	1
Racking Arm	1
Air Lock and Stopper	1
Temperature Gauge (Liquid Crystal)	1
Legs	3
Plastic Rivets	3
Plastic Feet	3

ASSEMBLY

Step 1: Confirm that all parts, required hardware, and tools are ready and available for assembly. Refer to the table above which includes a list of all parts and hardware that came with your ANVIL Crucible.

Step 2: Remove the lid and set the fermentor upside down. Locate the end of the leg with the hole on the side. Insert the leg while lining up the side hole with the rivet hole in the black plastic base. Press the rivet into the hole first and then insert the rivet pin to secure the rivet. Ensure the rivet is flush with the outside surface. Repeat steps for all three legs.

Step 3: Clean all parts and the fermentor tank prior to use with mild detergent, Powdered Brewery Wash or similar chlorine free product.

Step 4: Soak all parts in a non-chlorine sanitizer, and spray the inside of the tank and lid with sanitizer.

Step 5: Remove the locknut from the valve and insert the male threads of the valve into the large hole in the cone of the Crucible from the outside as shown in the drawing below. Make sure the o-ring is seated in the groove on the valve on the outside of the fermentor as shown. Install the Teflon washer over the male threads on the inside of the Crucible. Install and secure the NPT lock nut by hand. Hold the valve with one hand on the outside and locknut with the other hand on the inside of the Crucible. Tighten it firmly but not too tight that the valve doesn't rotate by hand.

Step 6: Install the dip tube assembly on the end of the valve. Tighten until the seal inside makes contact, then an additional ¼ turn. Tip: Orient the dip tube in the same direction as your valve handle. That way you'll know the position of the dip tube when the fermentor is full.

Step 7: Assemble the bottom dump as shown in Figure 3.

Step 8: Spray the inside walls of the fermentor with StarSan sanitizer, or fill it with your preferred non-chlorine sanitizer, including the lid. Then drain the fermentor completely and install the airlock and stopper and fill it with distilled water or vodka. The fermentor is now sanitized and ready to be filled!

WARNING!

Always ensure there is an airlock or blow off tube in place. Plugging the hole on the lid completely can cause the fermentation chamber to reach dangerous pressure levels and potentially cause serious injury or death!

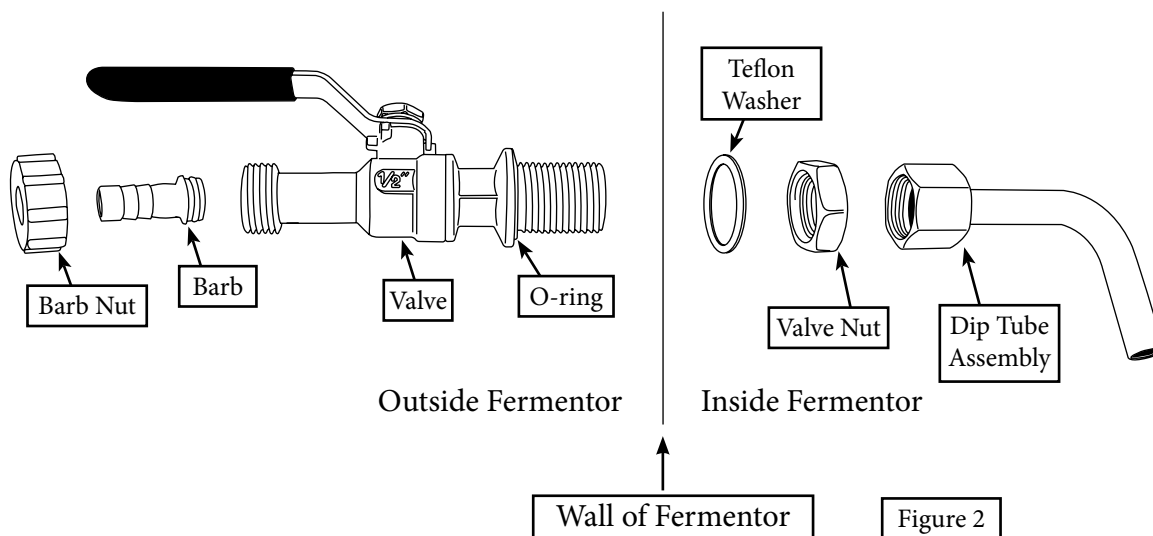
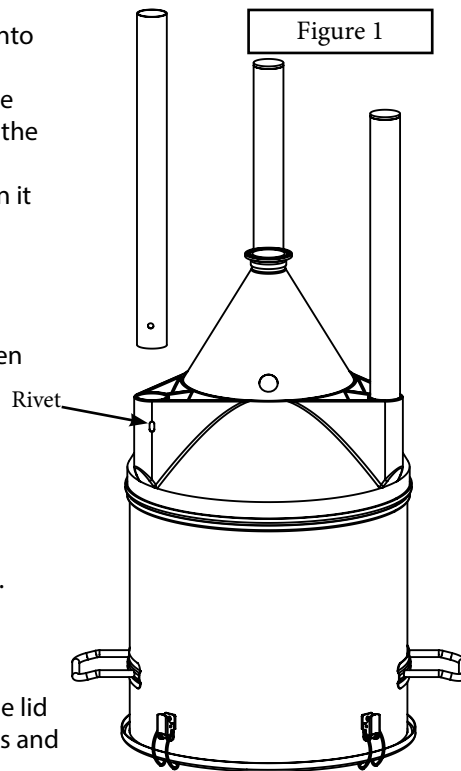

OPERATION

Step One: After sanitizing, fill your fermentor from the top so that it is no more than 3/4" full. That will allow enough room for the foam (krausen) from fermentation. Add your yeast and oxygenate. We recommend the ANVIL oxygenation wand. This will give your yeast all the oxygen it needs for proper fermentation. In about 12-24 hours you will see bubbling in the airlock.

Step Two: After a week to 10 days the bubbles will stop. Allow a few more days for the beer to fall clear. Install a 1/2" inside diameter hose (not included) on the barb. Remove the airlock and stopper to prevent the liquid in the airlock from getting sucked into your beer. Then rotate the valve so that the dip tube is horizontal. Begin draining the beer into your bottling bucket or keg by opening the valve. Slowly rotate the dip tube downward. Stop rotating when you see yeast or sediment pass through the hose. Then back it up a little and continue to drain.

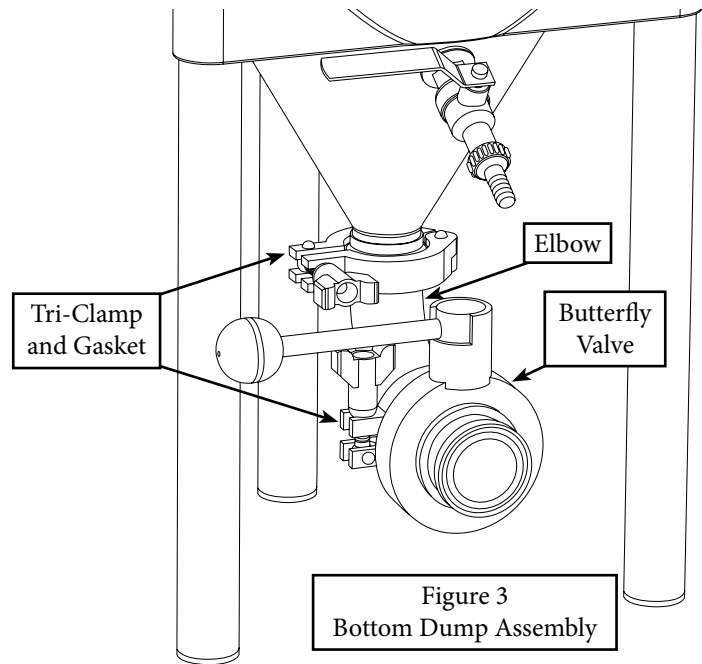

Warning: Never seal the yeast storage vessel! The yeast may create dangerous pressures that could burst the container!

TIP: controlling fermentation temperature is important for proper fermentation. The optional ANVIL cooling kit (ANV-CS-CARB) is ideal for precisely controlling fermentation temperatures.

Note: Level markings are accurate to +/- 0.25gal.

BOTTOM DUMP OPERATION

Now you're about to see the real benefit to a conical fermentor: the ease of trub (cold break) and yeast removal for secondary fermentation or yeast harvesting and quick and sanitary removal of wort samples. Typically, cold break is removed just after wort chilling, but prior to pitching the yeast (allow time for settling to the bottom of the tank). Remaining trub and flocculated yeast can be removed after primary fermentation.

TRUB AND YEAST DUMPING: Spray the inside of the butterfly valve with sanitizer. Remove the airlock to prevent the liquid in the airlock from sucking back into the fermentor. Place a suitable container under the valve and slowly open the valve draining the sediment into the container. Stop when beer begins to flow through the valve. If you are planning to reuse the yeast, see the section below. Tip: if you have a large amount of sediment or it has compacted over time, it may take one to two minutes for the flow to begin. Over time, yeast takes on the consistency of toothpaste (as opposed to molasses) and even commercial breweries have trouble with plugging. More frequent dumping earlier in the fermentation process will alleviate this. It is recommended to dump when primary fermentation has slowed, and then every few days until the yeast has all been removed. Leaving trub in the boil kettle will reduce the amount of trub carried into the fermentor and improve the quality of your beer. Consult any homebrewing text for recommended procedures.

HARVESTING YEAST: If you're harvesting the yeast, you'll need to purchase the (optional) yeast harvesting kit ANV-YeastHarvesting. Remove the cap and gasket and spray the inside of the butterfly valve with sanitizer a few minutes prior to installing the barbed fitting. Soak the barb, gasket and hose in sanitizer, then assemble onto the tank. A wide mouthed glass jar 16 or 32 oz works well for a yeast collection and storage vessel. Or an Erlenmeyer flask fitted with an airlock and stopper. If you have CO₂ available, purge the jar of oxygen before filling. Slowly open the valve and allow the trub to pass first and discard it. Collect the cream-colored yeast. If using a 16 or 32 oz mason jar, leave the lid a little loose so that CO₂ can escape. With proper sanitization techniques, yeast can be stored in the refrigerator for several weeks and harvested up to 4 times in a typical homebrew environment. Since you'll have plenty of yeast to pitch (reactivate in a starter if more than 2 weeks old) you'll find your ferments starting faster and progressing much more quickly. After harvesting spray the closed valve with sanitizer and reinstall the tri-clamp cap onto your butterfly valve.

CLEANING & MAINTENANCE

After use, rinse with hot water and completely disassemble the fermentor and fittings. Soak the fittings and seals in hot PBW solution or boil as in the sanitizing procedure. Scrub the fermentor and lid with a Scotch-brite green scouring pad and ordinary dish detergent (or your favorite non-chlorine cleanser such as PBW) and rinse and dry thoroughly.

Thoroughly dry all seals and o-rings and store them in a plastic bag and place inside the tank for the next use. Be sure to remove all the o-rings from the fittings to prevent from taking a "set". Install the lid to prevent dust from settling inside the unit during storage.

LEG EXTENSIONS (OPTIONAL)

Remove the lid and set the fermentor upside down. Use a small screwdriver to pop out the plastic rivet from each leg in the fermentor. Remove the short legs from the fermentor by gently pulling, twisting, and rocking the leg. Locate the end of the leg extension with the hole on the side and insert the leg while lining up the side hole with the rivet hole in the fermentor. Press to install the new rivets supplied with the leg extensions. Build the leg brace assembly first before installing onto the legs. Use a glass cleaner to install each grommet into each leg brace bar. After the 3 pieces are together, install onto the legs as shown.

7 GALLON CRUCIBLE ONLY: Do not use the tri-clamp elbow. Install the butterfly valve directly to the 1.5" tri-clamp port at the bottom of the fermentor.

Figure 4

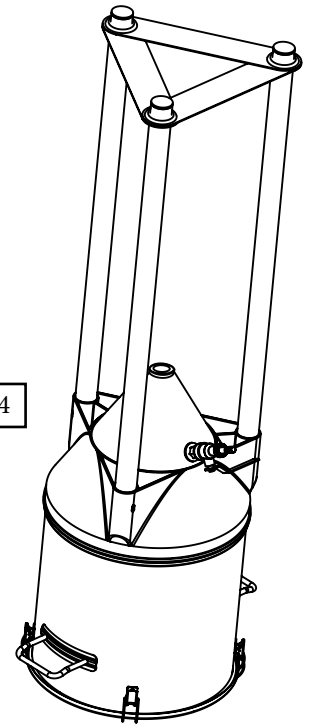

OPTIONAL ACCESSORIES

7 Gallon Crucible Cooling System - ANV-Crucible-CS-7gal

14 Gallon Crucible Cooling System - ANV-Crucible-CS-14gal

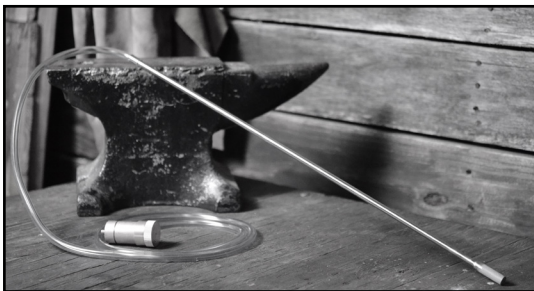

O2 Wand and Regulator - ANV-O2-WAND-REG

ANVIL BREWING EQUIPMENT PRODUCT WARRANTY

A. Limited Warranty

1. ANVIL Brewing Equipment warrants to the original purchaser that this product will be free from manufacturing defects in material workmanship for a period of one (1) year from the date of purchase by the customer. Proof of purchase is required. ANVIL Brewing Equipment's obligation to repair or replace defective materials or workmanship is the sole obligation of ANVIL Brewing Equipment under this limited warranty.
2. This product is for home use only. The limited warranty covers only those defects that arise as a result of normal use of the product and does not cover any other problems, including, but not limited to, those that arise as a result of:
 - a. Improper maintenance or modification;
 - b. Damage due to incorrect voltage or improper wiring by customer;
 - c. Operation outside of the product's specifications;
 - d. Carelessness or neglect to operate the product in accordance with instructions provided with the product;
 - e. Damaging the tamper label on the product;
 - f. Damage by over-tightening the fasteners;
 - g. Failure to follow cleaning and / or maintenance procedures; or
 - h. Exceeding published operational temperatures.
3. ANVIL Brewing Equipment reserves the right to request delivery of the defective component for inspection before processing the warranty claim. If ANVIL Brewing Equipment receives, during the applicable warranty period, notice of a defect in any component that is covered by the warranty, ANVIL Brewing Equipment shall either repair or replace the defective component with a new or rebuilt component at ANVIL Brewing Equipment's option.
4. ANVIL Brewing Equipment must be notified within seven (7) days of the delivery date of any shipping damage. Customer is responsible for shipping damage outside of this time period. Approval for return must be provided by ANVIL Brewing Equipment prior to any return. Customer is responsible for keeping all original packaging material for warranty returns. ANVIL Brewing Equipment is not responsible for damage from improperly packaged warranty returns, and these repair costs will be the sole responsibility of the customer. Shipping costs for warrantee returns are covered only for the contiguous United States.
5. ANVIL Brewing Equipment's limited warranty is valid in any country where the product is distributed.

B. Limitations of Warranty

1. Any implied warranty that is found to arise by way of state or federal law, including any implied warranty of merchantability or any implied warranty of fitness, is limited in duration to the terms of this limited warranty and is limited in scope of coverage to this warranty. ANVIL Brewing Equipment disclaims any express or implied warranty, including any implied warranty of fitness for a particular purpose or merchantability, on items excluded from coverage as set forth in this limited warranty.
2. ANVIL Brewing Equipment makes no warranty of any nature beyond that contained in this limited warranty. No one has authority to enlarge, amend, or modify this limited warranty, and
3. ANVIL Brewing Equipment does not authorize anyone to create any other obligation for it regarding this product.
4. ANVIL Brewing Equipment is not responsible for any representation, promise, or warranty made by any independent dealer or other person beyond what is expressly stated in this limited warranty. Any selling or servicing dealer is not ANVIL Brewing Equipment's agent, but an independent entity.

C. Limitations of Liability

1. The remedies provided in this warranty are the customer's sole and exclusive remedies.
2. Except for the obligations specifically set forth in this warranty, in no event shall ANVIL Brewing Equipment be liable for direct, indirect, special, incidental, or consequential damages, whether based on contract, tort, or any other legal theory and whether or not advised of the possibility of such damages.
3. This warranty does not cover, and in no event shall ANVIL Brewing Equipment be liable for, travel, lodging, or any other expense incurred due to manufacturing defects in material and workmanship, or any other reason.
4. Any performance of repairs after the warranty coverage period has expired or performance of repairs regarding anything excluded from coverage after this limited warranty
5. Shall be considered good-will repairs and they will not alter the terms of this limited warranty, or extend any warranty coverage period.
6. Venue for any legal proceedings relating to or arising out of this warranty shall be in Tippecanoe County, Indiana, United States, which courts will have exclusive jurisdiction.

D. Local Law

1. This warranty gives the customer specific legal rights. The customer may also have other rights that vary from state to state in the United States or other countries.
2. To the extent that this warranty is inconsistent with local law, it shall be deemed modified, only to the extent necessary to be consistent with such local law.